

CHIYODA



FITTING

- TOUCH CONNECTOR FIVE 3/2
- SPEED CONTROLLER 3/13
- TOUCH CONNECTOR 3/15
- TOUCH CONNECTOR SPEED CONTROLLER & TOUCH CONNERCTOR H TYPE SPEED CONTROLLER 3/19
- TOUCH CONNECTOR FUJI H TYPE & TOUCH CONNECTOR FUJI H TYPE SPEED CONTROLLER 3/21
- TUBE & BALANCER 3/24

FITTING

FOR PNEUMATIC COMPONENTS

TOUCH CONNECTOR FIVE

เป็นข้อต่อสำหรับงานลมทุกประเภท ระบายอุณหภูมิ และระบบลมในเครื่องจักรตัวข้อต่อสายลมออกแบบเป็นพิเศษ ล็อคแน่นและปลดออกง่ายใช้ได้กับสายลม โพลียูรีเทนและไนลอน ทำจากพลาสติกมีหลายรูปทรงให้เลือกตามการใช้งาน

Specification

Media	Compressed Air	Water
Working Temperature Range	-5~60 °C	5~40 °C
Max. Working Pressure	1MPa	0.3MPa
Working Vacuum Pressure	-100 KPa	



Materials

Part Name	Material
① Release Ring	PBT
② Guide	PBT
③ Lock Ring	Stainless
④ Packing	NBR
⑤ Body	PBT
⑥ Male Thread	Brass

HOW TO ORDER

F R 6 - 02 ML

No mark: Plastic and / or metal body type
R : Solid Plastic Body
Tube O.D.
4 : 4mm. 10 : 10mm.
6 : 6mm. 12 : 12mm.
8 : 8mm.
Thread size
M5 : M5x0.8 03 : R3/8.Rc3/8
01 : R1/8.Rc1/8 04 : R1/2.Rc1/2
02 : R1/4.Rc1/4 00 : Non Thread
M : Male Nipple
ML : Male Elbow
M2L : long Male Elbow
MT : Male Branch Tee
RT : Male Run Tee
MY : Male Branch Y
F : Female Connector
LC : L Connector
RC : Reducer
J : Joint (Different Joint)
FB : Female Bulkhead
BU : Bulkhead Union
U : Union (Different Union)
UL : Union Elbow
UT : Union Tee (Different Union Tee)
UY : Union Y (Different Union Y)
MS : Male Nipple (with Hex Key)

CONSTRUCTION

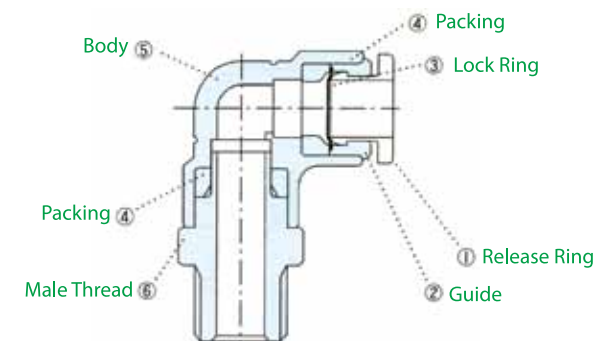

FITTING

FOR PNEUMATIC COMPONENTS

TOUCH CONNECTOR FIVE

ข้อต่อ "ชียอดะ" เหมาะสำหรับงานลมทุกประเภท ครอบคลุมและระบบลมในเครื่องจักร ซึ่งต้องทนความร้อนและสะเก็ดไฟ ตัวล๊อคสายลมออกแบบเป็นพิเศษ ล็อคได้แน่นและปลดออกได้ง่าย ใช้ได้กับสายลมหลายประเภท ทั้งโพลียูเรเทนและไนลอน โดยไม่ทำลายผิวสัมผัสของสายลม มีทั้งแบบทองเหลืองและพลาสติก

DIFFERENT UNION

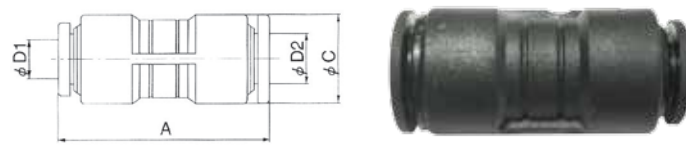

Model	A	ØC	Tube O.D.		Weight (g)
			ØD1	ØD2	
FR4-06U	28.4	12.0	4	6	2.6
FR6-08U	31.2	14.0	6	8	3.7
FR8-10U	33.8	17.0	8	10	5.6
FR10-12U	35.0	20.0	10	12	8.1

DIFFERENT UNION TEE

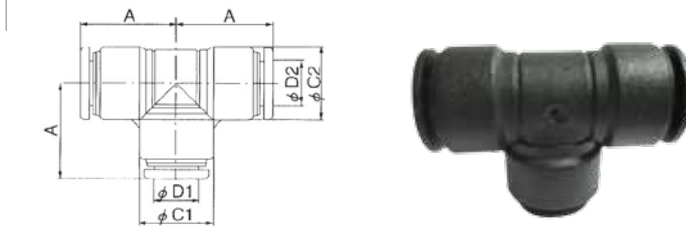

Model	A	ØC1	ØC2	Tube O.D.		Weight (g)
				ØD1	ØD2	
FR4-66UT	15.8	12.0	12.0	4	6	3.9
FR6-88UT	17.8	14.0	14.0	6	8	5.6
FR8-1010UT	19.8	17.0	17.0	8	10	8.7
FR10-1212UT	22.3	20.0	20.0	10	12	13.9

DIFFERENT UNION TEE

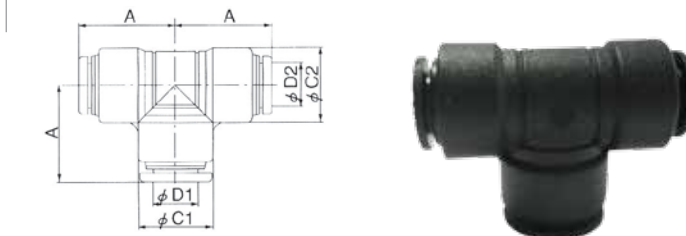

Model	A	ØC1	ØC2	Tube O.D.		Weight (g)
				ØD1	ØD2	
FR6-44UT	15.8	12.0	12.0	6	4	4.0
FR8-66UT	17.8	14.0	14.0	8	6	5.9
FR10-88UT	19.8	17.0	17.0	10	8	9.2
FR12-1010UT	22.3	20.0	20.0	12	10	14.4

DIFFERENT UNION Y

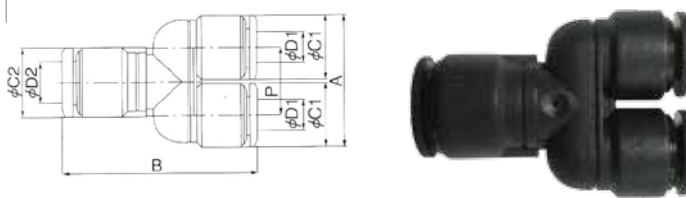

Model	A	B	ØC1	ØC2	Tube O.D.		P	Weight (g)
					ØD1	ØD2		
FR4-06UY	32.6	20.8	10.0	12.0	4	6	10.8	3.4
FR6-08UY	35.6	25.0	12.0	14.0	6	8	13.0	4.9
FR8-10UY	39.0	29.0	14.0	17.0	8	10	15.0	6.9
FR10-12UY	43.6	35.0	17.0	20.0	10	12	18.0	11.8

FITTING

FOR PNEUMATIC COMPONENTS

TOUCH CONNECTOR FIVE

ข้อต่อ "ชียอดะ" เหมาะสำหรับงานลมทุกประเภท ครอบคลุมและระบบลมในเครื่องจักร ซึ่งต้องทนความร้อนและสะเก็ดไฟ ตัวล๊อคสายลมออกแบบเป็นพิเศษ ล็อคได้แน่นและปลดออกได้ง่าย ใช้ได้กับสายลมหลายประเภท ทั้งโพลียูเรเทนและไนลอน โดยไม่ทำลายผิวสัมผัสของสายลม มีทั้งแบบทองเหลืองและพลาสติก

SINGLE BANJO

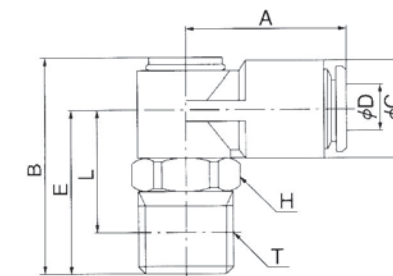

Model	A	B	ØC	Tube O.D. ØD	E	Spanner Flats H	L	Thread T	Weight (g)
F4-M5S1	20.7	24.8	11.0	4	14.5	10.0	11.5	M5X0.8	7.7
F4-01S1	20.7	24.8	11.0	4	18.5	10.0	14.5	R1/8	9.7
F4-02S1	20.7	24.8	11.0	4	21.5	14.0	15.5	R1/4	15.0
F6-M5S1	22.3	26.8	13.0	6	15.5	12.0	12.0	M5X0.8	10.1
F6-01S1	22.3	26.8	13.0	6	19.5	12.0	15.5	R1/8	12.1
F6-02S1	22.3	26.8	13.0	6	22.5	14.0	16.5	R1/4	18.1
F6-03S1	22.3	26.8	13.0	6	23.5	17.0	17.1	R3/8	25.6
F8-01S1	24.8	28.9	15.0	8	20.5	14.0	16.5	R1/8	17.0
F8-02S1	24.8	28.9	15.0	8	23.5	14.0	17.5	R1/4	21.0
F8-03S1	24.8	28.9	15.0	8	24.5	17.0	18.1	R3/8	29.0
F10-01S1	26.8	32.1	17.0	10	21.5	17.0	17.5	R1/8	27.8
F10-02S1	26.8	32.1	17.0	10	24.5	17.0	18.5	R1/4	30.3
F10-03S1	26.8	32.1	17.0	10	25.5	17.0	19.1	R3/8	34.8
F10-04S1	26.8	32.1	17.0	10	29.5	21.0	21.5	R1/2	50.3
F12-02S1	29.3	37.1	20.0	12	26.0	19.0	20.0	R1/4	41.1
F12-03S1	29.3	37.1	20.0	12	27.0	19.0	20.6	R3/8	41.6
F12-04S1	29.3	37.1	20.0	12	31.0	21.0	23.0	R1/2	55.1

REDUCER

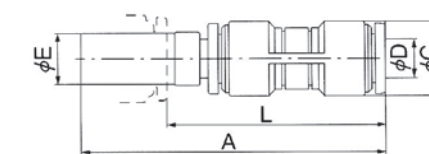

Model	A	ØC	Tube O.D. ØD	ØE	L	Weight (g)
FR4-6RC	44.4	10.0	4	6	31.9	2.4
FR4-8RC	46.4	10.0	4	8	32.7	2.7
FR6-8RC	48.9	12.0	6	8	35.2	3.3
FR6-10RC	50.9	12.0	6	10	36.3	3.8
FR8-10RC	53.5	14.0	8	10	38.9	4.9
FR8-12RC	54.5	14.0	8	12	39.1	5.4
FR10-12RC	57.2	17.0	10	12	41.8	7.6

FITTING

FOR PNEUMATIC COMPONENTS

TOUCH CONNECTOR FIVE

ข้อต่อ "ชียอดะ" เหมาะสำหรับงานลมทุกประเภท ครอบคลุมและระบบลมในเครื่องจักร ซึ่งต้องทนความร้อนและสะเก็ดไฟ ตัวข้อต่อสายลมออกแบบเป็นพิเศษ ล็อคได้แน่นและปลดออกได้ง่าย ใช้ได้กับสายลมหลายประเภท ทั้งโพลีเอทิลีนและไนลอน โดยไม่ทำลายผิวสัมผัสของสายลม มีทั้งแบบทองเหลืองและพลาสติก

JOINT

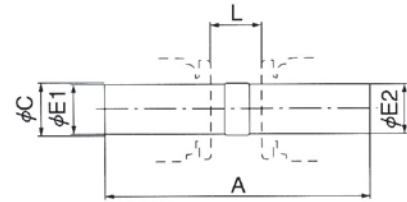

Model	A	ØC	ØE1	ØE2	L	Weight (g)
Black body						
FR4-4J	29.0	4.5	4	4	5.0	0.3
FR6-6J	31.0	6.5	6	6	6.0	0.7
FR8-8J	34.0	8.5	8	8	6.6	1.0
FR10-10J	37.0	11.0	10	10	7.8	1.7
FR12-12J	39.0	13.0	12	12	8.2	2.6

DIFFERENT JOINT

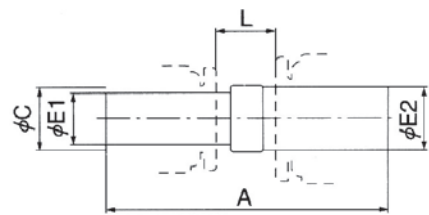

Model	A	ØC	ØE1	ØE2	L	Weight (g)
Black body						
FR4-6J	30.0	6.5	4	6	5.5	0.5
FR4-8J	32.0	8.5	4	8	6.3	0.8
FR6-8J	33.0	8.5	6	8	6.8	0.9
FR6-10J	35.0	11.0	6	10	7.9	1.4
FR8-10J	36.0	11.0	8	10	7.7	1.5
FR8-12J	37.0	13.0	8	12	7.9	2.0
FR10-12J	38.0	13.0	10	12	8.0	2.3

FITTING

FOR PNEUMATIC COMPONENTS

TOUCH CONNECTOR FIVE

ข้อต่อ "ชียอดะ" เหมาะสำหรับงานลมทุกประเภท ครอบคลุมและระบบลมในเครื่องจักร ซึ่งต้องทนความร้อนและสะเก็ดไฟ ตัวข้อต่อสายลมออกแบบเป็นพิเศษ ล็อคได้แน่นและปลดออกได้ง่าย ใช้ได้กับสายลมหลายประเภท ทั้งโพลีเอทิลีนและไนลอน โดยไม่ทำลายผิวสัมผัสของสายลม มีทั้งแบบทองเหลืองและพลาสติก

MALE CONNECTOR

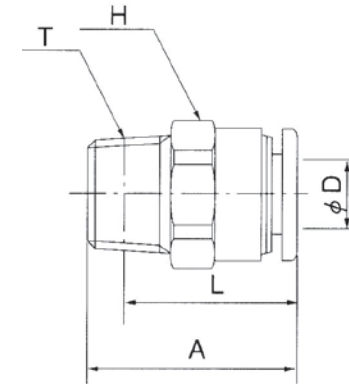

Model	A	Tube O.D. ØD	Spanner Flats H	L	Thread T	Weight (g)
Black body						
F4-M5M	16.3	4	10.0	13.3	M5X0.8	4.1
F4-01M	19.3		10.0	15.3	R1/8	6.4
F4-02M	22.3		14.0	16.3	R1/4	14.3
F6-M5M	17.5	6	12.0	14.5	M5X0.8	6.3
F6-01M	19.3		12.0	15.3	R1/8	7.6
F6-02M	22.3		14.0	16.3	R1/4	16.0
F6-03M	24.3	8	17.0	17.9	R3/8	25.5
F8-01M	23.2		14.0	19.2	R1/8	11.9
F8-02M	22.3		14.0	16.3	R1/4	11.6
F8-03M	24.3	10	17.0	17.9	R3/8	23.7
F10-01M	23.8		17.0	19.8	R1/8	18.6
F10-02M	25.6		17.0	19.6	R1/4	19.4
F10-03M	26.3	12	17.0	19.9	R3/8	22.0
F10-04M	28.3		21.0	20.3	R1/2	46.1
F12-02M	27.3		19.0	21.3	R1/4	23.5
F12-03M	28.3	12	19.0	21.9	R3/8	26.0
F12-04M	29.3		21.0	21.3	R1/2	38.8

MALE CONNECTOR

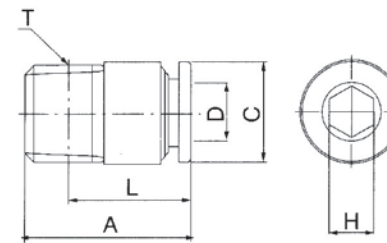

Model	A	ØC	Tube O.D. ØD	Spanner Flats H	L	Thread T	Weight (g)
Black body							
F4-M5MS	16.3	9.8	4	2.5	13.3	M5X0.8	3.8
F4-01MS	16.8	9.8		3.0	12.8	R1/8	5.3
F6-M5MS	17.5	12.5		2.5	14.5	M5X0.8	5.7
F6-01MS	18.5	12.5	6	4.0	14.5	R1/8	6.8
F6-02MS	19.8	14.0		4.0	13.8	R1/4	13.0
F8-01MS	22.8	14.5		5.0	18.8	R1/8	10.5
F8-02MS	21.8	14.5	8	6.0	15.8	R1/4	11.5
F8-03MS	21.8	17.0		6.0	15.4	R3/8	22.5
F10-01MS	23.8	17.5		10	5.0	19.8	R1/8
F10-02MS	25.6	17.5	8.0		19.6	R1/4	15.2
F10-03MS	23.3	17.5	8.0		16.9	R3/8	18.9
F10-04MS	22.3	21.0	12	8.0	14.3	R1/2	33.7
F12-02MS	27.4	20.0		8.0	21.4	R1/4	18.2
F12-03MS	24.3	20.0		8.0	17.9	R3/8	18.9
F12-04MS	25.3	21.0	12	8.0	17.3	R1/2	35.5

FITTING

FOR PNEUMATIC COMPONENTS

TOUCH CONNECTOR FIVE

ข้อต่อ "ชียอดะ" เหมาะสำหรับงานลมทุกประเภท ครอบคลุมและระบบลมในเครื่องจักร ซึ่งต้องทนความร้อนและสะเก็ดไฟ ตัวข้อต่อสายลมออกแบบเป็นพิเศษ ล็อคได้แน่นและปลดออกได้ง่าย ใช้ได้กับสายลมหลายประเภท ทั้งโพลีเอทิลีนและไนลอน โดยไม่ทำลายผิวสัมผัสของสายลม มีทั้งแบบทองเหลืองและพลาสติก

MALE ELBOW

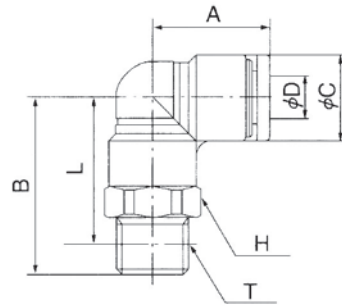

Model	A	B	φC	Tube O.D.	Spanner Flats H	L	Thread T	Weight (g)
Black body				φD				
F4-M5ML		19.0		4	10.0	16.0	M5X0.8	6.4
F4-01ML	14.8	22.5	10.0	4	10.0	18.5	R1/8	9.8
F4-02ML		26.5		4	14.0	20.5	R1/4	18.8
F6-M5ML		20.0		6	12.0	17.0	M5X0.8	7.5
F6-01ML	15.8	24.5	12.0	6	12.0	20.5	R1/8	11.2
F6-02ML		27.5		6	14.0	21.5	R1/4	19.6
F6-03ML		29.5		6	17.0	23.1	R3/8	30.6
F8-01ML		26.5		8	14.0	22.5	R1/8	14.0
F8-02ML	17.8	29.5	14.0	8	14.0	23.5	R1/4	18.5
F8-03ML		31.5		8	17.0	25.1	R3/8	32.9
F10-01ML		29.5		10	17.0	25.5	R1/8	20.2
F10-02ML	19.8	32.5	17.0	10	17.0	26.5	R1/4	24.3
F10-03ML		33.5		10	17.0	27.1	R3/8	31.3
F10-04ML		36.5		10	21.0	28.5	R1/2	57.9
F12-02ML		35.0		12	19.0	29.0	R1/4	26.1
F12-03ML	22.3	36.0	20.0	12	21.0	29.6	R3/8	33.5
F12-04ML		39.0		12	21.0	31.0	R1/2	54.4

LONG MALE ELBOW

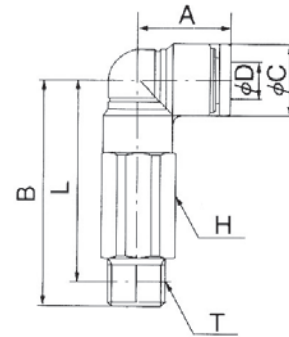

Model	A	B	φC	Tube O.D.	Spanner Flats H	L	Thread T	Weight (g)
Black body				φD				
F4-01M2L		34.5		4	10.0	30.5	R1/8	17.2
F4-02M2L	14.8	37.5	10.0	4	14.0	31.5	R1/4	34.8
F6-01M2L		38.5		6	12.0	34.5	R1/8	23.5
F6-02M2L	15.8	41.5	12.0	6	14.0	35.5	R1/4	37.3
F8-01M2L		42.5		8	14.0	38.5	R1/8	31.6
F8-02M2L	17.8	45.5	14.0	8	14.0	39.5	R1/4	36.5
F8-03M2L		46.5		8	17.0	40.1	R3/8	59.5
F10-02M2L		51.5		10	17.0	45.5	R1/4	54.3
F10-03M2L	19.8	52.5	17.0	10	17.0	46.1	R3/8	61.3
F10-04M2L		55.5		10	21.0	47.5	R1/2	106.3
F12-02M2L		57.0		12	19.0	51.0	R1/4	84.4
F12-03M2L	22.3	58.0	20.0	12	21.0	51.6	R3/8	89.8
F12-04M2L		61.0		12	21.0	53.0	R1/2	105.5

FITTING

FOR PNEUMATIC COMPONENTS

TOUCH CONNECTOR FIVE

ข้อต่อ "ชียอดะ" เหมาะสำหรับงานลมทุกประเภท ครอบคลุมและระบบลมในเครื่องจักร ซึ่งต้องทนความร้อนและสะเก็ดไฟ ตัวข้อต่อสายลมออกแบบเป็นพิเศษ ล็อคได้แน่นและปลดออกได้ง่าย ใช้ได้กับสายลมหลายประเภท ทั้งโพลีเอทิลีนและไนลอน โดยไม่ทำลายผิวสัมผัสของสายลม มีทั้งแบบทองเหลืองและพลาสติก

MALE BRANCH TEE

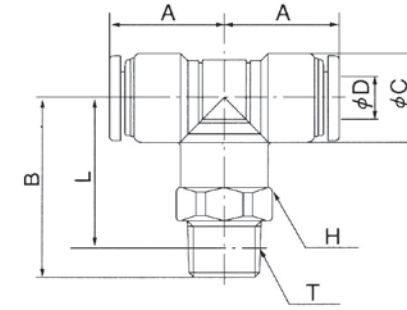

Model	A	B	φC	Tube O.D.	Spanner Flats H	L	Thread T	Weight (g)
Black body				φD				
F4-M5MT		19.0		4	10.0	16.0	M5X0.8	7.2
F4-01MT	14.8	22.5	10.0	4	10.0	18.5	R1/8	10.6
F4-02MT		26.5		4	14.0	20.5	R1/4	19.6
F6-M5MT		20.0		6	12.0	17.0	M5X0.8	8.4
F6-01MT	15.8	24.5	12.0	6	12.0	20.5	R1/8	12.1
F6-02MT		27.5		6	14.0	21.5	R1/4	20.5
F6-03MT		29.5		6	17.0	23.1	R3/8	31.8
F8-01MT		26.5		8	14.0	22.5	R1/8	15.2
F8-02MT	17.8	29.5	14.0	8	14.0	23.5	R1/4	19.7
F8-03MT		31.5		8	17.0	25.1	R3/8	34.1
F10-01MT		29.5		10	17.0	25.5	R1/8	21.3
F10-02MT	19.8	32.5	17.0	10	17.0	26.5	R1/4	24.6
F10-03MT		33.5		10	17.0	27.1	R3/8	30.7
F10-04MT		36.5		10	21.0	28.5	R1/2	56.4
F12-02MT		35.0		12	19.0	29.0	R1/4	27.0
F12-03MT	22.3	36.0	20.0	12	21.0	29.6	R3/8	33.6
F12-04MT		39.0		12	21.0	31.0	R1/2	53.5

MALE RUN TEE

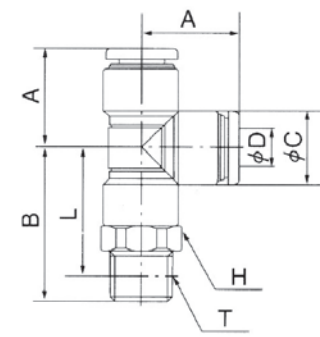

Model	A	B	φC	Tube O.D.	Spanner Flats H	L	Thread T	Weight (g)
Black body				φD				
F4-M5RT		19.0		4	10.0	16.0	M5X0.8	7.2
F4-01RT	14.8	22.5	10.0	4	10.0	18.5	R1/8	10.6
F4-02RT		26.5		4	14.0	20.5	R1/4	19.6
F6-M5RT		20.0		6	12.0	17.0	M5X0.8	8.4
F6-01RT	15.8	24.5	12.0	6	12.0	20.5	R1/8	12.1
F6-02RT		27.5		6	14.0	21.5	R1/4	20.5
F6-03RT		29.5		6	17.0	23.1	R3/8	31.8
F8-01RT		26.5		8	14.0	22.5	R1/8	15.2
F8-02RT	17.8	29.5	14.0	8	14.0	23.5	R1/4	19.7
F8-03RT		31.5		8	17.0	25.1	R3/8	34.1
F10-01RT		29.5		10	17.0	25.5	R1/8	21.3
F10-02RT	19.8	32.5	17.0	10	17.0	26.5	R1/4	24.6
F10-03RT		33.5		10	17.0	27.1	R3/8	30.7
F10-04RT		36.5		10	21.0	28.5	R1/2	56.4
F12-02RT		35.0		12	19.0	29.0	R1/4	27.0
F12-03RT	22.3	36.0	20.0	12	21.0	29.6	R3/8	33.6
F12-04RT		39.0		12	21.0	31.0	R1/2	53.5

FITTING

FOR PNEUMATIC COMPONENTS

TOUCH CONNECTOR FIVE

ข้อต่อ "ชียอดะ" เหมาะสำหรับงานลมทุกประเภท ครอบคลุมและระบบลมในเครื่องจักร ซึ่งต้องทนความร้อนและสะเก็ดไฟ ตัวข้อต่อสายลมออกแบบเป็นพิเศษ ล็อคได้แน่นและปลดออกได้ง่าย ใช้ได้กับสายลมหลายประเภท ทั้งโพลียูเรเทนและไนลอน โดยไม่ทำลายผิวสัมผัสของสายลม มีทั้งแบบทองเหลืองและพลาสติก

MALE BRANCH Y

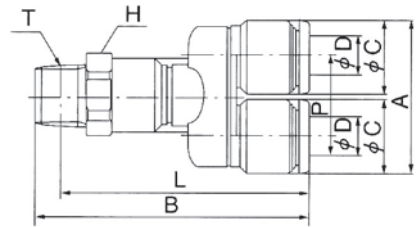

Model	A	B	ØC	Tube O.D. ØD	Spanner Flats H	L	P	Thread T	Weight (g)
Black body									
F4-M5MY	35.8				10.0	32.8		M5X0.8	6.6
F4-01MY	20.8	39.3	10.0	4	10.0	35.3	10.8	R1/8	9.7
F4-02MY		43.3			14.0	37.3		R1/4	19.5
F6-M5MY	38.4				12.0	35.4		M5X0.8	9.1
F6-01MY	25.0	42.9	12.0	6	12.0	38.9	13.0	R1/8	12.2
F6-02MY		45.9			14.0	39.9		R1/4	19.8
F6-03MY		47.9			17.0	41.5		R3/8	33.0
F8-01MY	46.4				14.0	42.4		R1/8	15.9
F8-02MY	29.0	49.4	14.0	8	14.0	43.4	15.0	R1/4	19.8
F8-03MY		51.4			17.0	45.0		R3/8	32.5
F10-01MY	52.7				17.0	48.7		R1/8	25.4
F10-02MY	35.0	55.7	17.0	10	17.0	49.7	18.0	R1/4	28.5
F10-03MY		56.7			17.0	50.3		R3/8	34.5
F10-04MY		59.7			21.0	51.7		R1/2	57.0
F12-02MY	61.3				19.0	55.3		R1/4	39.4
F12-03MY	41.0	60.3	20.0	12	21.0	53.9	21.0	R3/8	43.8
F12-04MY		63.3			21.0	55.3		R1/2	58.0

FEMALE CONNECTOR

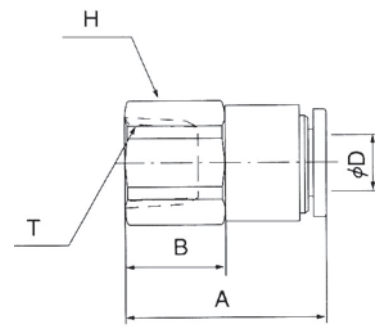

Model	A	B	Tube O.D. ØD	Spanner Flats H	Thread T	Weight (g)
Black body						
F4-01F	21.3	11.0	4	12.0	Rc1/8	10.2
F4-02F	24.3	12.5		17.0	Rc1/4	20.0
F6-01F	21.8	11.0	6	12.0	Rc1/8	12.7
F6-02F	24.8	13.0		17.0	Rc1/4	20.3
F6-03F	25.8	13.5		21.0	Rc3/8	33.5
F8-01F	22.8	11.5	8	14.0	Rc1/8	16.4
F8-02F	25.8	13.5		17.0	Rc1/4	20.3
F8-03F	26.8	14.0		21.0	Rc3/8	33.0
F10-02F	26.8	14.0	10	17.0	Rc1/4	29.0
F10-03F	27.8	14.5		21.0	Rc3/8	35.0
F10-04F	30.8	16.5		24.0	Rc1/2	39.9
F12-02F	27.8	14.5	12	21.0	Rc1/4	39.9
F12-03F	28.8	15.5		21.0	Rc3/8	44.3
F12-04F	31.8	17.0		24.0	Rc1/2	58.5

FITTING

FOR PNEUMATIC COMPONENTS

TOUCH CONNECTOR FIVE

ข้อต่อ "ชียอดะ" เหมาะสำหรับงานลมทุกประเภท ครอบคลุมและระบบลมในเครื่องจักร ซึ่งต้องทนความร้อนและสะเก็ดไฟ ตัวข้อต่อสายลมออกแบบเป็นพิเศษ ล็อคได้แน่นและปลดออกได้ง่าย ใช้ได้กับสายลมหลายประเภท ทั้งโพลียูเรเทนและไนลอน โดยไม่ทำลายผิวสัมผัสของสายลม มีทั้งแบบทองเหลืองและพลาสติก

FEMALE BULK

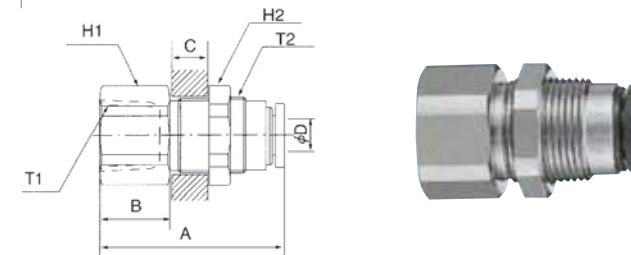

Model	A	B	C	Tube O.D. ØD	Spanner Flats H	Thread T	Weight (g)	
Black body			max		H1 H2	T1 T2		
F4-01FB	29.8	8.5		4	14.0	14.0	Rc1/8 M12x1	21.8
F6-02FB	34.3	13.0		6	17.0	17.0	Rc1/4 M14x1	34.2
F8-02FB	33.8	12.5	10.0	8	19.0	19.0	Rc1/4 M16x1	42.8
F10-03FB	34.3	13.0		10	24.0	24.0	Rc3/8 M20x1	66.1
F12-03FB	34.3	12.0		12	24.0	24.0	Rc3/8 M22x1	68.2

BULKHEAD UNION

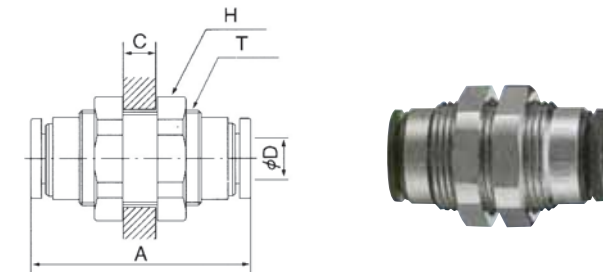

Model	A	C	Tube O.D. ØD	Spanner Flats H	Thread T	Weight (g)
Black body		max				
F4-00BU	32.6		4	14.0	M12x1	21.4
F6-00BU	32.6		6	17.0	M14x1	29.8
F8-00BU	32.6	10	8	19.0	M16x1	31.8
F10-00BU	32.6		10	24.0	M20x1	47.5
F12-00BU	34.6		12	24.0	M22x1	54.8

BLIND PLUG

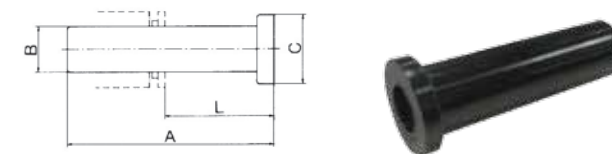

Model	A	ØB	ØC	L	Weight (g)
Black body					
RP-4	30.0	4.0	8.0	15.0	0.5
RP-6	36.0	6.0	10.0	19.7	1.0
RP-8	36.0	8.0	12.0	19.0	2.0
RP-10	40.0	10.0	14.0	22.2	2.5
RP-12	43.0	12.0	16.0	23.6	4.0

FITTING

FOR PNEUMATIC COMPONENTS

SPEED CONTROLLER $\alpha \cdot \beta$

เหมาะสำหรับกระบอสูบและสายลมทุกประเภท ควบคุม FLOW RATE ได้ง่าย มีให้เลือกหลายขนาด

Specification

Media	Compressed Air
Working Temperature Range	-5~60°C (23~140°F)
Max. Working Pressure	0.05MPa ~ 0.7MPa
Tube used	<ul style="list-style-type: none"> ▶ Touch tube ▶ TE, TP, MTP Polyurethane Tube ▶ TN Nylon tube



HOW TO ORDER

F B 6 R - 01 SC - O

Five β

R : Resin Body Material
Tube O.D.
4 : 4mm. 10 : 10mm.
6 : 6mm. 12 : 12mm.
8 : 8mm.
Thread size
M5 : M5x0.8 02 : R1X4 04 : Rc1/2
01 : R1X8 03 : R3/8
Speed Controller
0 : Mater-Out Type
I : Mater-In Type

FITTING

FOR PNEUMATIC COMPONENTS

SPEED CONTROLLER $\alpha \cdot \beta$

เหมาะสำหรับกระบอสูบและสายลมทุกประเภท ควบคุม FLOW RATE ได้ง่าย มีให้เลือกหลายขนาด

SPEED CONTROLLER α

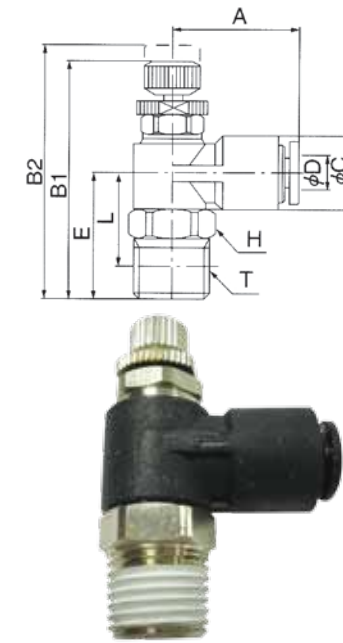

Model	A	B1	B2	ØC	Tube O.D.	E	Spanner Flats H	L	Thread T	Weight (g)
F4R-M5SC-0(I)	35.7	38.9			4	16.0	12.0	13.0	M5X0.8	23.0
F4R-01SC-0(I)	39.2	42.4				19.5	12.0	15.5	R1/8	26.0
F6R-M5SC-0(I)	35.7	38.9			6	16.0	12.0	13.0	M5X0.8	22.0
F6R-01SC-0(I)	39.2	42.4				19.5	12.0	15.5	R1/8	25.0
F6R-02SC-0(I)	44.9	50.1			6	23.5	14.0	17.5	R1/4	37.0
F8R-01SC-0(I)	41.9	47.1	15			20.5	14.0	16.5	R1/8	32.5
F8R-02SC-0(I)	44.9	50.1			8	23.5	14.0	17.5	R1/4	37.5
F8R-03SC-0(I)	49.7	56.0				25.5	17.0	19.1	R3/8	60.0
F10R-02SC-0(I)	48.7	55.0			10	24.5	17.0	18.5	R1/4	54.0
F10R-03SC-0(I)	49.7	56.0				25.5	17.0	19.1	R3/8	61.0
F10R-04SC-0(I)	53.7	60.7			10	29.5	21.0	21.5	R1/2	79.0
F12R-03SC-0(I)	52.7	61.8				12	27.0	19.0	20.6	R3/8
F12R-04SC-0(I)	56.7	65.8			31.0		21.0	23.0	R1/2	96.0

SPEED CONTROLLER β

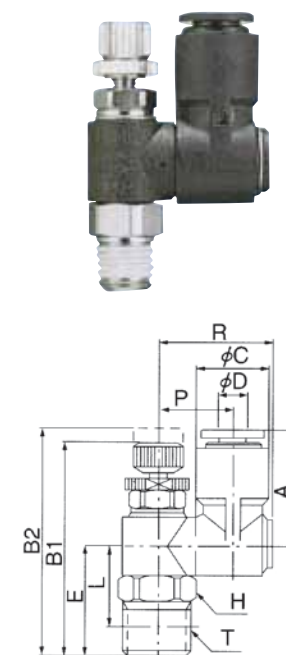

Model	A	B1	B2	ØC	Tube O.D.	E	Spanner Flats H	L	P	R	Thread T	Weight (g)
FB4R-M5SC-0(I)	35.7	38.9			4	15.5	12.0	12.5			M5X0.8	26.5
FB4R-01SC-0(I)	39.2	42.4				19.0	12.0	15.0				R1/8
FB6R-M5SC-0(I)	35.7	38.9			6	15.5	12.0	12.5			M5X0.8	25.5
FB6R-01SC-0(I)	39.2	42.4				19.0	12.0	15.0				R1/8
FB6R-02SC-0(I)	44.9	50.1			6	23.0	14.0	17.0			R1/4	41.5
FB8R-01SC-0(I)	41.9	47.1	15.0			20.0	14.0	16.0	17.0	25.5		R1/8
FB8R-02SC-0(I)	44.9	50.1			8	23.0	14.0	17.0			R1/4	42.0
FB8R-03SC-0(I)	49.7	56.0				25.5	17.0	19.1				R3/8
FB10R-02SC-0(I)	48.7	55.0			10	24.5	17.0	18.5			R1/4	62.5
FB10R-03SC-0(I)	49.7	56.0				25.5	17.0	19.1				R3/8
FB10R-04SC-0(I)	53.7	60.7			10	29.5	21.0	21.5			R1/2	87.5
FB12R-03SC-0(I)	52.7	61.8				12	26.5	19.0	20.1			R3/8
FB12R-04SC-0(I)	56.7	65.8			30.5		21.0	22.5				R1/2

FITTING

FOR PNEUMATIC COMPONENTS

TOUCH CONNECTOR

ข้อต่อ "ชียอดะ" เหมาะสำหรับงานลมทุกประเภท ครอบคลุมและระบบลมในเครื่องจักร ซึ่งต้องทนความร้อนและสะเก็ดไฟ ตัวล๊อคสายลมออกแบบเป็นพิเศษ ล็อคได้แน่นและปลดออกได้ง่าย ใช้ได้กับสายลมหลายประเภท ทั้งโพลียูเรเทนและไนลอน โดยไม่ทำลายผิวสัมผัสของสายลม มีทั้งแบบทองเหลืองและพลาสติก



Specification

Media	Compressed Air
Working Temperature Range	-5~60 °C (23~140 °F)
Max. Working Pressure	1 MPa
Working Vacuum Pressure	-100 KPa
Tube used ● Standard Type: TE, TR, MTP Polyurethane Tube ● TN Nylon Tube	
● "S" Type: Stainless Pipe ● Copper Pipe	

Materials

Part Name	Material
Main Body	
Metal type	Brass
Resin type	Polyacetal
Male Adaptor	Brass
"ACTIVE" Edge	Steel
Release Lever	Brass plated zinc die-casting
Stopper	Polyacetal
Stop Ring	Stainless
O-ring	NBR

CONSTRUCTION

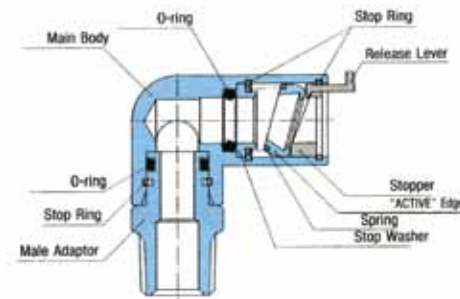

NIPPLE CONNECTOR [METAL BODY]

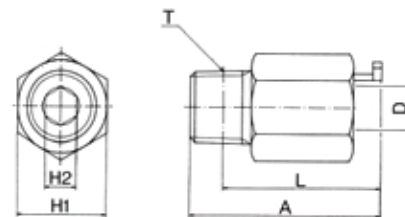

Model	A	Tube O.D. ØD	Spanner Flats		L	Thread T	Effective Section Area (mm ²)		Weight (g)
			H1	H2			Polyurethane Tube	Nylon Tube	
CKN-4-M5	29.7	4	12.0		25.7	M5X0.8	2.7	2.9	13.8
CKN-4-01	26.7	4	12.0	3.0	22.7	R1/8	3.3	5.5	13.0
CKN-4-02	26.7	4	14.0	3.0	20.7	R1/4	3.3	5.5	20.4
CKN-6-01	32.5	6	14.0	4.0	28.5	R1/8	10.5	14.0	19.2
CKN-6-02	32.5	6	14.0	4.0	26.5	R1/4	11.0	14.5	22.6
CKN-6-03	32.5	6	17.0	4.0	26.1	R3/8	11.0	14.5	40.2
CKN-8-01	36.5	8	17.0	5.0	32.5	R1/8	15.0	20.0	32.6
CKN-8-02	34.5	8	17.0	6.0	28.5	R1/4	17.5	27.5	30.8
CKN-8-03	31.5	8	17.0	6.0	25.1	R3/8	17.5	27.5	32.0
CKN-10-01	41.0	10	19.0	5.0	37.0	R1/8	20.0	28.0	41.4
CKN-10-02	39.0	10	19.0	6.0	33.0	R1/4	30.0	42.0	38.4
CKN-10-03	38.0	10	19.0	8.0	31.6	R3/8	30.0	42.0	41.6
CKN-10-04	35.0	10	21.0	8.0	27.0	R1/2	30.0	42.0	54.4
CKN-12-02	46.5	12	21.0	7.0	40.5	R1/4	43.0	50.0	52.0
CKN-12-03	44.0	12	21.0	9.0	37.6	R3/8	43.0	50.0	52.4
CKN-12-04	44.5	12	21.0	9.0	36.5	R1/2	45.0	55.0	63.2

FITTING

FOR PNEUMATIC COMPONENTS

TOUCH CONNECTOR FIVE

ข้อต่อ "ชียอดะ" เหมาะสำหรับงานลมทุกประเภท ครอบคลุมและระบบลมในเครื่องจักร ซึ่งต้องทนความร้อนและสะเก็ดไฟ ตัวล๊อคสายลมออกแบบเป็นพิเศษ ล็อคได้แน่นและปลดออกได้ง่าย ใช้ได้กับสายลมหลายประเภท ทั้งโพลียูเรเทนและไนลอน โดยไม่ทำลายผิวสัมผัสของสายลม มีทั้งแบบทองเหลืองและพลาสติก

ELBOW CONNECTOR [METAL BODY]

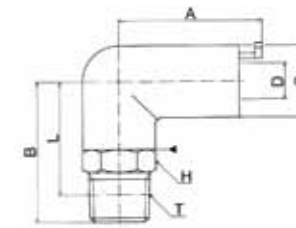

Model	A	B	ØC	Tube O.D. ØD	Spanner Flats H	L	Thread T	Effective Section Area (mm ²)		Weight (g)
								Polyurethane Tube	Nylon Tube	
CKL-4-M5	26.2	21.5	12.0	4	10.0	17.5	M5X0.8	2.9	3.0	28.2
CKL-4-01	26.2	25.5	12.0	4	10.0	21.5	R1/8	3.1	5.4	31.8
CKL-4-02	26.2	28.5	12.0	4	14.0	22.5	R1/4	3.1	5.4	36.2
CKL-6-01	30.0	27.0	14.0	6	12.0	23.0	R1/8	9.0	10.0	44.6
CKL-6-02	30.0	30.0	14.0	6	14.0	24.0	R1/4	9.1	10.5	45.0
CKL-6-03	30.0	31.0	14.0	6	17.0	24.6	R3/8	9.1	10.5	55.4
CKL-8-01	31.5	28.0	16.0	8	14.0	24.0	R1/8	15.5	22.0	60.8
CKL-8-02	31.5	31.0	16.0	8	14.0	25.0	R1/4	15.5	22.0	61.4
CKL-8-03	31.5	32.0	16.0	8	17.0	25.6	R3/8	15.5	22.0	68.8
CKL-10-01	35.0	28.0	18.0	10	17.0	24.0	R1/8	18.5	22.0	62.4
CKL-10-02	35.0	31.0	18.0	10	17.0	25.0	R1/4	26.0	33.0	67.8
CKL-10-03	35.0	32.0	18.0	10	17.0	25.6	R3/8	26.0	33.0	71.6
CKL-10-04	35.0	36.0	18.0	10	19.0	28.0	R1/2	26.0	33.0	83.6
CKL-12-02	38.5	35.0	21.0	12	19.0	29.0	R1/4	36.0	41.0	95.2
CKL-12-03	38.5	36.0	21.0	12	19.0	29.6	R3/8	40.0	48.0	99.8
CKL-12-04	38.5	39.0	21.0	12	21.0	31.0	R1/2	40.0	48.0	113.2

TEE'S CONNECTOR [METAL BODY]

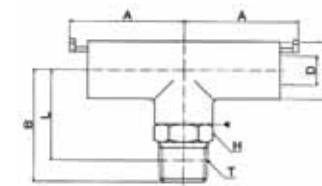

Model	A	B	ØC	Tube O.D. ØD	Spanner Flats H	L	Thread T	Effective Section Area (mm ²)		Weight (g)
								Polyurethane Tube	Nylon Tube	
CKT-4-M5	26.2	21.5	12.0	4	10.0	17.5	M5X0.8	3.3	3.4	38.2
CKT-4-01	26.2	25.5	12.0	4	10.0	21.5	R1/8	4.9	6.7	41.6
CKT-4-02	26.2	28.5	12.0	4	14.0	22.5	R1/4	4.9	6.7	46.6
CKT-6-01	30.0	27.0	14.0	6	12.0	23.0	R1/8	12.5	13.0	59.6
CKT-6-02	30.0	30.0	14.0	6	14.0	24.0	R1/4	12.5	13.0	62.4
CKT-6-03	30.0	31.0	14.0	6	17.0	24.6	R3/8	13.0	14.0	71.5
CKT-8-01	31.5	28.0	16.0	8	14.0	24.0	R1/8	23.0	25.0	61.6
CKT-8-02	31.5	31.0	16.0	8	14.0	25.0	R1/4	23.0	25.0	83.0
CKT-8-03	31.5	32.0	16.0	8	17.0	25.6	R3/8	23.0	25.0	86.2
CKT-10-01	35.0	28.0	18.0	10	17.0	24.0	R1/8	25.0	29.0	85.6
CKT-10-02	35.0	31.0	18.0	10	17.0	25.0	R1/4	36.0	41.0	85.4
CKT-10-03	35.0	32.0	18.0	10	17.0	25.6	R3/8	36.0	41.0	89.8
CKT-10-04	35.0	36.0	18.0	10	19.0	28.0	R1/2	36.0	41.0	106.0
CKT-12-02	38.5	35.0	21.0	12	19.0	29.0	R1/4	42.0	45.0	129.0
CKT-12-03	38.5	36.0	21.0	12	19.0	29.6	R3/8	55.0	60.0	130.8
CKT-12-04	38.5	39.0	21.0	12	21.0	31.0	R1/2	55.0	60.0	141.8

FITTING

FOR PNEUMATIC COMPONENTS

TOUCH CONNECTOR

ข้อต่อ "ชียอดะ" เหมาะสำหรับงานลมทุกประเภท ครอบคลุมและระบบลมในเครื่องจักร ซึ่งต้องทนความร้อนและสะเก็ดไฟ ตัวข้อต่อสายลมออกแบบเป็นพิเศษ ล็อคได้แน่นและปลดออกได้ง่าย ใช้ได้กับสายลมหลายประเภท ทั้งโพลียูรีเทนและไนลอน โดยไม่ทำลายผิวสัมผัสของสายลม มีทั้งแบบทองเหลืองและพลาสติก

SERVICE TEE'S [METAL BODY]

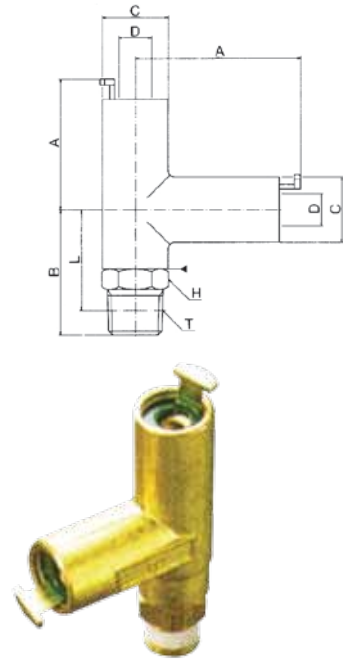

Model	A	B	ØC	Tube O.D. ØD	Spanner Flats H	L	Thread T	Effective Section Area (mm ²)		Weight (g)
								Polyurethane Tube	Nylon Tube	
CKS-4-M5	27.2	21.5	12.0	4	10.0	18.0	M5X0.8	3.3	3.4	40.6
CKS-4-01	27.2	25.5	12.0	4	10.0	21.5	R1/8	4.9	6.7	44.4
CKS-4-02	27.2	28.5	12.0	4	14.0	22.5	R1/4	4.9	6.7	47.0
CKS-6-01	30.7	26.5	14.0	6	12.0	22.5	R1/8	12.5	13.0	59.6
CKS-6-02	30.7	29.5	14.0	6	14.0	23.5	R1/4	12.5	13.0	62.8
CKS-6-03	30.7	30.5	14.0	6	17.0	24.1	R3/8	12.5	13.0	76.0
CKS-8-01	31.7	27.5	16.0	8	14.0	23.5	R1/8	23.0	25.0	76.8
CKS-8-02	31.7	30.5	16.0	8	14.0	24.5	R1/4	25.0	27.0	80.8
CKS-8-03	31.7	31.5	16.0	8	17.0	25.3	R3/8	25.0	27.0	85.4
CKS-10-01	36.4	28.0	18.0	10	17.0	24.0	R1/8	25.0	29.0	91.0
CKS-10-02	36.4	31.0	18.0	10	17.0	25.0	R1/4	36.0	41.0	94.2
CKS-10-03	36.4	32.0	18.0	10	17.0	25.6	R3/8	36.0	41.0	101.2
CKS-10-04	36.4	36.0	18.0	10	21.0	28.0	R1/2	36.0	41.0	111.2
CKS-12-02	40.4	35.0	21.0	12	19.0	29.0	R1/4	42.0	45.0	136.0
CKS-12-03	40.4	36.0	21.0	12	19.0	29.6	R3/8	55.0	60.0	138.8
CKS-12-04	40.4	39.0	21.0	12	21.0	31.0	R1/2	55.0	60.0	153.6

NIPPLE UNION [METAL BODY]

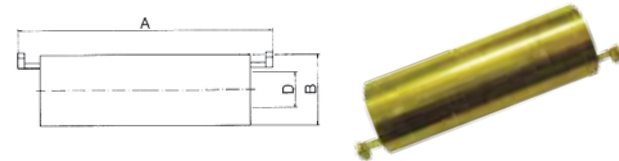

Model	A	ØB	Tube O.D. ØD	Effective Section Area (mm ²)		Weight (g)
				Polyurethane Tube	Nylon Tube	
CUN-4-00	51.4	12.0	4	3.3	5.5	27.8
CUN-6-00	56.4	14.0	6	10.5	14.0	37.8
CUN-8-00	56.4	16.0	8	18.0	27.0	44.8
CUN-10-00	63.8	18.0	10	28.5	36.0	56.4
CUN-12-00	69.8	21.0	12	47.0	55.0	79.2

UNION ELBOW [METAL BODY]

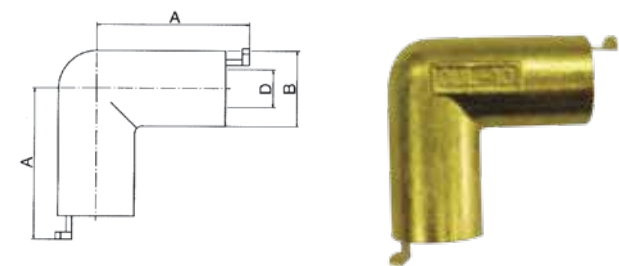

Model	A	ØB	Tube O.D. ØD	Effective Section Area (mm ²)		Weight (g)
				Polyurethane Tube	Nylon Tube	
CUL-4-00	27.2	12.0	4	3.2	4.4	31.0
CUL-6-00	30.7	14.0	6	9.1	10.5	43.2
CUL-8-00	31.7	16.0	8	16.0	21.0	52.6
CUL-10-00	36.4	18.0	10	26.0	33.0	70.6
CUL-12-00	40.4	21.0	12	36.0	41.0	102.4

FITTING

FOR PNEUMATIC COMPONENTS

TOUCH CONNECTOR

ข้อต่อ "ชียอดะ" เหมาะสำหรับงานลมทุกประเภท ครอบคลุมและระบบลมในเครื่องจักร ซึ่งต้องทนความร้อนและสะเก็ดไฟ ตัวข้อต่อสายลมออกแบบเป็นพิเศษ ล็อคได้แน่นและปลดออกได้ง่าย ใช้ได้กับสายลมหลายประเภท ทั้งโพลียูรีเทนและไนลอน โดยไม่ทำลายผิวสัมผัสของสายลม มีทั้งแบบทองเหลืองและพลาสติก

UNION TEE [METAL BODY]

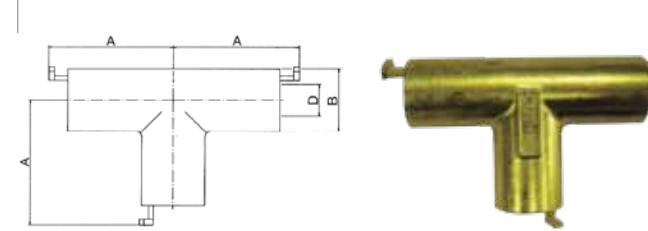

Model	A	ØB	Tube O.D. ØD	Effective Section Area (mm ²)		Weight (g)
				Polyurethane Tube	Nylon Tube	
CUT-4-00	27.2	12.0	4	4.9	6.7	42.8
CUT-6-00	30.7	14.0	6	12.5	13.0	61.4
CUT-8-00	31.7	16.0	8	23.0	25.0	72.0
CUT-10-00	36.4	18.0	10	34.0	38.0	96.2
CUT-12-00	40.4	21.0	12	60.0	65.0	138.2

BULK HEAD UNION [METAL BODY]

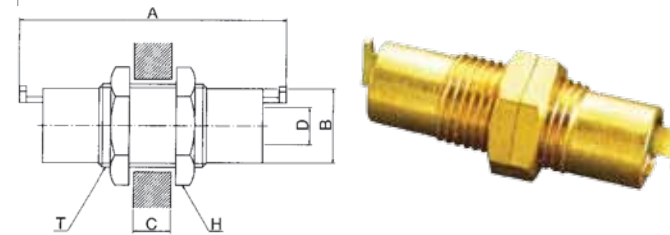

Model	A	ØB	C max	Tube O.D. ØD	Spanner Flats H	Thread T	Effective Section Area (mm ²)		Weight (g)
							Polyurethane Tube	Nylon Tube	
CUB-4-00	51.4	12.0	15.0	4	17.0	M14X1.5	3.3	5.5	37.8
CUB-6-00	56.4	14.0	15.0	6	19.0	M16X1.5	10.5	14.0	48.8
CUB-8-00	56.4	16.0	15.0	8	22.0	M18X1.5	18.0	27.0	63.8
CUB-10-00	63.8	18.0	15.0	10	24.0	M20X1.5	28.5	36.0	73.6
CUB-12-00	69.8	21.0	15.0	12	27.0	M24X2	47.0	55.0	107.2

LONG ELBOW [METAL BODY]

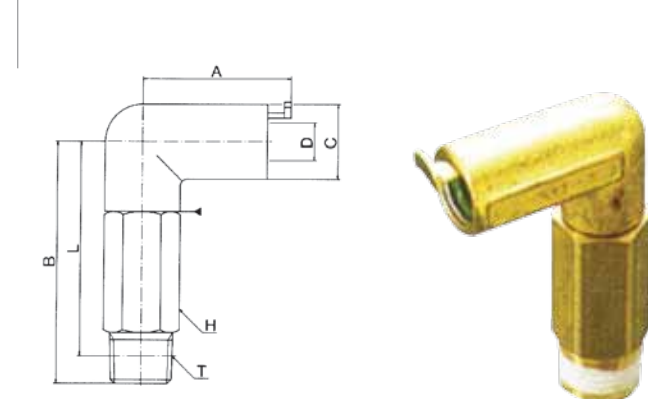

Model	A	B	ØC	Tube O.D. ØD	Spanner Flats H	L	Thread T	Effective Section Area (mm ²)		Weight (g)
								Polyurethane Tube	Nylon Tube	
CKL-4-01-2L	26.2	42.5	12.0	4	10.0	38.5	R1/8	3.1	5.4	45.6
CKL-4-02-2L	26.2	42.5	12.0	4	14.0	39.5	R1/4	3.1	5.4	55.0
CKL-6-01-2L	29.7	46.0	14.0	6	12.0	42.0	R1/8	9.1	10.5	57.4
CKL-6-02-2L	29.7	49.0	14.0	6	14.0	43.0	R1/4	9.1	10.5	68.0
CKL-8-01-2L	31.2	49.0	16.0	8	14.0	45.0	R1/8	14.0	20.0	79.4
CKL-8-02-2L	31.2	52.0	16.0	8	14.0	46.0	R1/4	14.0	20.0	80.4
CKL-8-03-2L	31.2	53.0	16.0	8	17.0	46.6	R3/8	14.0	20.0	96.4
CKL-10-02-2L	34.9	54.0	18.0	10	17.0	48.0	R1/4	25.0	31.0	106.0
CKL-10-03-2L	34.9	55.0	18.0	10	17.0	48.6	R3/8	25.0	31.0	101.8
CKL-10-04-2L	34.9	59.0	18.0	10	21.0	51.0	R1/2	25.0	31.0	134.6
CKL-12-02-2L	38.4	59.0	21.0	12	19.0	53.0	R1/4	36.0	41.0	145.0
CKL-12-03-2L	38.4	60.0	21.0	12	19.0	53.6	R3/8	40.0	48.0	145.2
CKL-12-04-2L	38.4	65.0	21.0	12	21.0	57.0	R1/2	40.0	48.0	166.2

FITTING

FOR PNEUMATIC COMPONENTS

TOUCH CONNECTOR SPEED CONTROLLER

เหมาะสำหรับระบบท่อและสายลมทุกประเภท ควบคุม FLOWRATE ได้ง่าย มีให้เลือกหลายขนาด

SPEED CONTROLLER

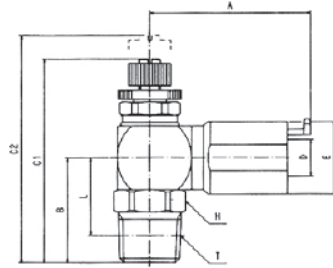

Model	A	B	C1	C2	Tube O.D. ØD	E	Spanner Flats H	L	Thread T	Weight (g)
C4-M5SC-0(I)	30.7	15.9	36.2	39.3	4	12.0	12.0	11.9	M5X0.8	38
C4-01SC-0(I)	30.7	19.0	39.3	42.4	4	12.0	12.0	15.0	R1/8	40
C6-M5SC-0(I)	33.5	15.9	36.2	39.3	6	14.0	12.0	11.9	M5X0.8	40
C6-01SC-0(I)	33.5	19.0	39.3	42.4	6	14.0	12.0	15.0	R1/8	44
C6-02SC-0(I)	33.5	22.0	42.3	45.4	6	14.0	14.0	16.0	R1/4	48
C8-01SC-0(I)	34.3	22.0	41.9	46.9	8	16.0	14.0	16.0	R1/8	56
C8-02SC-0(I)	34.3	23.0	44.9	49.9	8	16.0	14.0	17.0	R1/4	60
C8-03SC-0(I)	34.3	24.0	45.9	50.9	8	16.0	17.0	17.6	R3/8	68
C10-02SC-0(I)	39.5	24.5	48.3	54.3	10	17.0	17.0	18.5	R1/4	82
C10-03SC-0(I)	39.5	25.5	49.3	55.3	10	17.0	17.0	19.1	R3/8	88
C10-04SC-0(I)	39.5	29.5	53.3	59.3	10	17.0	21.0	21.5	R1/2	106
C12-03SC-0(I)	43.5	26.5	52.0	61.0	12	21.0	19.0	20.1	R3/8	126
C12-04SC-0(I)	43.5	30.5	56.0	65.0	12	21.0	21.0	22.5	R1/2	144

SPEED CONTROLLER

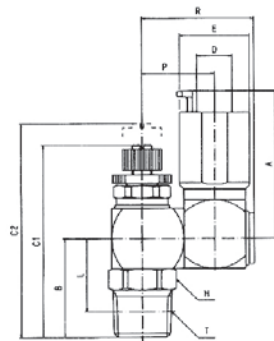

Model	A	B	C1	C2	Tube O.D. ØD	E	Spanner Flats H	L	P	R	Thread T	Weight (g)
CB4-M5SC-0(I)	30.7	15.9	36.2	39.3	4	12.0	12.0	11.9	14.0	22.0	M5X0.8	50
CB4-01SC-0(I)	30.7	19.0	39.3	42.4	4	12.0	12.0	15.0	14.0	22.0	R1/8	52
CB6-M5SC-0(I)	34.3	15.9	36.2	39.3	6	14.0	12.0	11.9	14.0	22.0	M5X0.8	52
CB6-01SC-0(I)	34.4	19.0	39.3	42.4	6	14.0	12.0	15.0	14.0	22.0	R1/8	58
CB6-02SC-0(I)	34.4	22.0	42.3	45.4	6	14.0	14.0	16.0	14.0	22.0	R1/4	62
CB8-01SC-0(I)	35.4	22.0	41.9	46.9	8	16.0	14.0	16.0	16.5	25.5	R1/8	70
CB8-02SC-0(I)	35.4	23.0	44.9	49.9	8	16.0	14.0	17.0	16.5	25.5	R1/4	88
CB8-03SC-0(I)	35.4	24.0	45.9	50.9	8	16.0	17.0	17.6	16.5	25.5	R3/8	96
CB10-02SC-0(I)	40.4	24.5	48.3	54.3	10	17.0	17.0	18.5	20.2	30.9	R1/4	120
CB10-03SC-0(I)	40.4	25.5	49.3	55.3	10	17.0	17.0	19.1	20.2	30.9	R3/8	126
CB10-04SC-0(I)	40.4	29.5	53.3	59.3	10	17.0	21.0	21.5	20.2	30.9	R1/2	144
CB12-03SC-0(I)	44.4	26.5	52.0	61.0	12	21.0	19.0	20.1	21.1	32.9	R3/8	174
CB12-04SC-0(I)	44.4	30.5	56.0	65.0	12	21.0	21.0	22.5	21.1	32.9	R1/2	192

FITTING

FOR PNEUMATIC COMPONENTS

TOUCH CONNECTOR H-TYPE SPEED CONTROLLER

เหมาะสำหรับระบบท่อและสายลมทุกประเภท ควบคุม FLOWRATE ได้ง่าย มีให้เลือกหลายขนาด

SPEED CONTROLLER

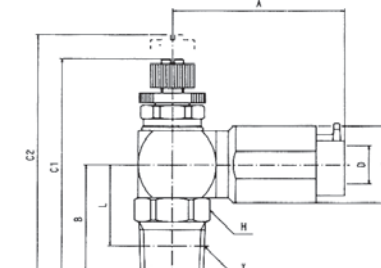

Model	A	B	C1	C2	Tube O.D. ØD	E	Spanner Flats H	L	Thread T	Weight (g)
C6-M5SCH-0(I)	34.4	15.9	36.2	39.3	6	14.0	12.0	11.9	M5X0.8	43
C6-01SCH-0(I)	34.4	19.0	39.3	42.4	6	14.0	12.0	15.0	R1/8	47
C6-02SCH-0(I)	34.4	22.0	42.3	45.4	6	14.0	14.0	16.0	R1/4	51
C8-01SCH-0(I)	35.4	22.0	41.9	46.9	8	16.0	14.0	16.0	R1/8	60
C8-02SCH-0(I)	35.4	23.0	44.9	49.9	8	16.0	14.0	17.0	R1/4	64
C8-03SCH-0(I)	35.4	24.0	45.9	50.9	8	16.0	17.0	17.6	R3/8	72
C10-02SCH-0(I)	40.4	24.5	48.3	54.3	10	17.0	17.0	18.5	R1/4	87
C10-03SCH-0(I)	40.4	25.5	49.3	55.3	10	17.0	17.0	19.1	R3/8	93
C10-04SCH-0(I)	40.4	29.5	53.3	59.3	10	17.0	21.0	21.5	R1/2	111
C12-03SCH-0(I)	44.4	26.5	52.0	61.0	12	21.0	19.0	20.1	R3/8	133
C12-04SCH-0(I)	44.4	30.5	56.0	65.0	12	21.0	21.0	22.5	R1/2	151

SPEED CONTROLLER

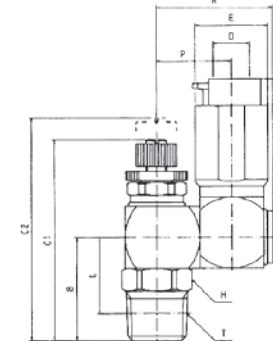

Model	A	B	C1	C2	Tube O.D. ØD	E	Spanner Flats H	L	P	R	Thread T	Weight (g)
CB6-M5SCH-0(I)	34.4	15.9	36.2	39.3	6	14.0	12.0	11.9	14.0	22.0	M5X0.8	55
CB6-01SCH-0(I)	34.4	19.0	39.3	42.4	6	14.0	12.0	15.0	14.0	22.0	R1/8	61
CB6-02SCH-0(I)	34.4	22.0	42.3	45.4	6	14.0	14.0	16.0	14.0	22.0	R1/4	65
CB8-01SCH-0(I)	35.4	22.0	41.9	46.9	8	16.0	14.0	16.0	16.5	25.5	R1/8	74
CB8-02SCH-0(I)	35.4	23.0	44.9	49.9	8	16.0	14.0	17.0	16.5	25.5	R1/4	92
CB8-03SCH-0(I)	35.4	24.0	45.9	50.9	8	16.0	17.0	17.6	16.5	25.5	R3/8	100
CB10-02SCH-0(I)	40.4	24.5	48.3	54.3	10	17.0	17.0	18.5	20.2	30.9	R1/4	125
CB10-03SCH-0(I)	40.4	25.5	49.3	55.3	10	17.0	17.0	19.1	20.2	30.9	R3/8	131
CB10-04SCH-0(I)	40.4	29.5	53.3	59.3	10	17.0	21.0	21.5	20.2	30.9	R1/2	149
CB12-03SCH-0(I)	44.4	26.5	52.0	61.0	12	21.0	19.0	20.1	21.1	32.9	R3/8	182
CB12-04SCH-0(I)	44.4	30.5	56.0	65.0	12	21.0	21.0	22.5	21.1	32.9	R1/2	200

FITTING

FOR PNEUMATIC COMPONENTS

TOUCH CONNECTOR Fuji SERIES

ข้อต่อ "ชิโยดะ" เหมาะสำหรับงานลมทุกประเภท ครอบคลุมและระบบลมในเครื่องจักร ซึ่งต้องทนความร้อนและสะเก็ดไฟ ตัวข้อต่อสายลมออกแบบเป็นพิเศษ ล็อคได้แน่นและปลดออกได้ง่าย ใช้ได้กับสายลมหลายประเภท ทั้งโพลีเอทิลีนและไนลอน โดยไม่ทำลายผิวสัมผัสของสายลม มีทั้งแบบทองเหลืองและพลาสติก

TOUCH CONNECTOR Fuji H TYPE

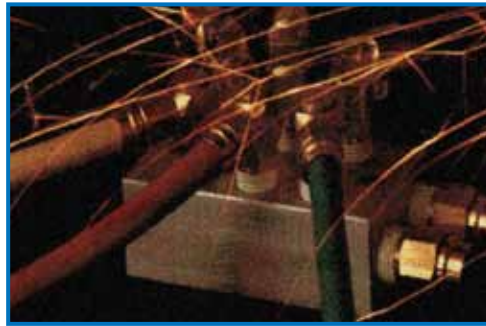

1. มีหัวแค็ปโลหะเป็นอุปกรณ์มาตรฐาน เป็นที่ปลดข้อต่อสายลม และป้องกันสายลมจากสะเก็ดไฟ
2. มีหลายรุ่นหลายแบบให้เลือกใช้ตามความเหมาะสม
3. หมายเลขรุ่นแกะด้วยเลเซอร์ประทับอยู่บนชิ้นส่วน ทำให้ง่ายต่อการแยกแยะ

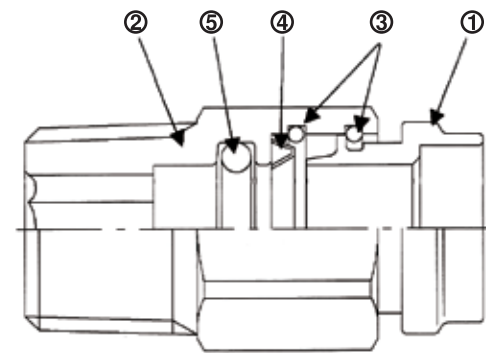

Material	
① Release Ring	Brass
② Body	Brass, Brass
③ Stop Ring	Stainless Steel
④ Lock Ring	Phosphor Bronze
⑤ O-Ring	NBR
Specification	
Media	Compressed Air, Industrial Water*1
Max. Working Pressure	1MPa*2
Working Temp. Range	-5~60 °C (No Freeze)
Tube Used	L-Flex LE, LE-S, ALE Touch Tube TE-AF

*1) Brass Plated Zink Die-casting body must be only for compressed air.
*2) Use under max. working surge pressure for the industrial water.

<How to Order -Model->

※ - ※ ※ - ※

Tube Internal O.D.	6: φ6, 8: φ8, 10: φ10, 12: φ12, B※: Speed Controller β
Thread Size	01:R1/8, 02:R1/4, 03:R3/8, 04:R1/2 M5: M5 x 0.8, OO: Union
Shape	M: Male Connector, ML: Male Elbow, S1: Single Banjo U: Union, UT: Union Tee SC: Speed Controller
Function	H: For Welding Environment

MALE CONNECTOR

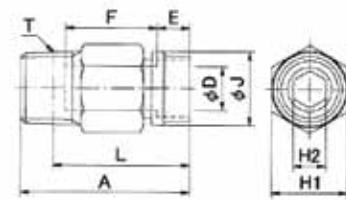

Model	A	Tube O.D. ØD	Outer Depth E	Inner Depth F	Spanner Flats		ØJ	L	Thread T
					H1	H2			
6-M5M-H	27.1	6.0	6.0	16.1	12.0	-	11.5	23.6	M5 X 0.8
6-01M-H	27.0				12.0	4.0		23.0	R1/8
6-02M-H	25.5				14.0	4.0		19.5	R1/4
6-03M-H	26.5				17.0	4.0		20.1	R3/8
8-01M-H	32.5	8.0	6.0	16.8	14.0	5.0	13.5	28.5	R1/8
8-02M-H	31.0				14.0	6.0		25.0	R1/4
8-03M-H	26.5				17.0	6.0		20.1	R3/8
10-01M-H	34.6				17.0	5.0		30.6	R1/8
10-02M-H	35.9	10.0	7.0	17.6	17.0	6.0	16.5	29.9	R1/4
10-03M-H	33.9				17.0	8.0		27.5	R3/8
10-04M-H	30.9				21.0	8.0		22.9	R1/2
12-02M-H	38.9				19.0	7.0		32.9	R1/4
12-03M-H	34.9	12.0	7.0	19.2	19.0	9.0	18.5	28.5	R3/8
12-04M-H	32.9				21.0	9.0		24.9	R1/2

FITTING

FOR PNEUMATIC COMPONENTS

TOUCH CONNECTOR Fuji SERIES

ข้อต่อ "ชิโยดะ" เหมาะสำหรับงานลมทุกประเภท ครอบคลุมและระบบลมในเครื่องจักร ซึ่งต้องทนความร้อนและสะเก็ดไฟ ตัวข้อต่อสายลมออกแบบเป็นพิเศษ ล็อคได้แน่นและปลดออกได้ง่าย ใช้ได้กับสายลมหลายประเภท ทั้งโพลีเอทิลีนและไนลอน โดยไม่ทำลายผิวสัมผัสของสายลม มีทั้งแบบทองเหลืองและพลาสติก

TOUCH CONNECTOR Fuji H TYPE

MALE ELBOW

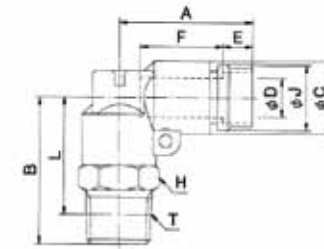

Model	A	B	ØC	Tube O.D. ØD	Outer Depth E	Inner Depth F	Spanner Flats H	ØJ	L	Thread T
6-M5ML-H	23.0	25.3	13.0	6.0	6.0	16.1	12.0	11.5	19.0	M5 X 0.8
6-01ML-H	26.0						12.0		22.0	R1/8
6-02ML-H	29.0						14.0		23.0	R1/4
6-03ML-H	30.0	27.0	15.0	8.0	6.0	16.8	17.0	13.5	23.6	R3/8
8-01ML-H	27.0						14.0		23.0	R1/8
8-02ML-H	30.0						14.0		24.0	R1/4
8-03ML-H	31.0						17.0		24.6	R3/8
10-01ML-H	28.0	29.8	17.0	10.0	7.0	17.6	17.0	16.5	24.0	R1/8
10-02ML-H	31.0						17.0		25.0	R1/4
10-03ML-H	32.0						17.0		25.6	R3/8
10-04ML-H	36.0						21.0		28.0	R1/2
12-02ML-H	34.5	32.4	19.0	12.0	7.0	19.2	19.0	18.5	28.5	R1/4
12-03ML-H	35.5						19.0		29.1	R3/8
12-04ML-H	38.5						21.0		30.5	R1/2

SINGLE BANJO

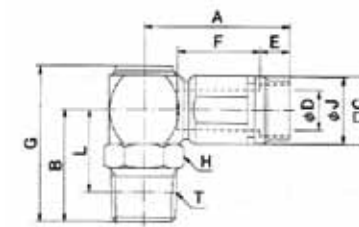

Model	A	B	ØC	Tube O.D. ØD	Outer Depth E	Inner Depth F	G	Spanner Flats H	ØJ	L	Thread T
6-01S1-H	19.0	27.5	12.0	6.0	6.0	16.1	26.8	12.0	11.5	15.0	R1/8
6-02S1-H	22.0						14.0	16.0		R1/4	
6-03S1-H	23.0						17.0	16.6		R3/8	
8-01S1-H	20.0	29.5	14.0	8.0	6.0	16.8	28.9	14.0	13.5	16.0	R1/8
8-02S1-H	23.0						14.0	17.0		R1/4	
8-03S1-H	24.0						17.0	17.6		R3/8	
10-01S1-H	21.5						17.0	17.5		R1/8	
10-02S1-H	24.5	33.4	17.0	10.0	7.0	17.6	35.1	17.0	16.5	18.5	R1/4
10-03S1-H	25.5						17.0	19.1		R3/8	
10-04S1-H	29.5						40.1	21.0		21.5	R1/2
12-02S1-H	25.5						37.1	19.0		19.5	R1/4
12-03S1-H	35.9	35.9	19.0	12.0	7.0	19.2	38.1	19.0	18.5	20.1	R3/8
12-04S1-H	30.5						42.1	21.0		22.5	R1/2

FITTING

FOR PNEUMATIC COMPONENTS

TOUCH CONNECTOR Fuji SERIES

ข้อต่อ "ชิโยดะ" เหมาะสำหรับงานลมทุกประเภท ครอบคลุมสเปกตรัมและระบบลมในเครื่องจักร ซึ่งต้องทนความร้อนและสะเก็ดไฟ ตัวคือคสายลมออกแบบเป็นพิเศษ ล็อคได้แน่นและปลดออกได้ง่าย ใช้ได้กับสายลมหลายประเภท ทั้งโพลียูเรเทนและไนลอน โดยไม่ทำลายผิวสัมผัสของสายลม มีทั้งแบบทองเหลืองและพลาสติก

TOUCH CONNECTOR Fuji H TYPE

UNION

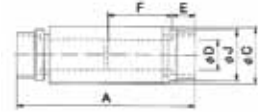

Model	A	φC	Tube O.D. φD	Outer Depth E	Inner Depth F	φJ
6-00U-H	45.2	13.0	6.0	6.0	16.1	16.1
8-00U-H	46.6	15.0	8.0	6.0	16.8	16.8
10-00U-H	50.2	17.0	10.0	7.0	17.6	17.6
12-00U-H	53.4	19.0	12.0	7.0	19.2	19.2

UNION Tee

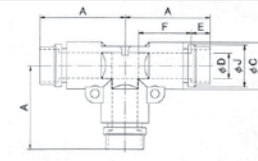

Model	A	φC	Tube O.D. φD	Outer Depth E	Inner Depth F	φJ
6-00UT-H	25.3	13.0	6.0	6.0	16.1	16.1
8-00UT-H	27.0	15.0	8.0	6.0	16.8	16.8
10-00UT-H	29.8	17.0	10.0	7.0	17.6	17.6
12-00UT-H	32.4	19.0	12.0	7.0	19.2	19.2

*) Tee Body is Brass Plated Zinc Die-casting, only for compressed air

Speed Controller α Type

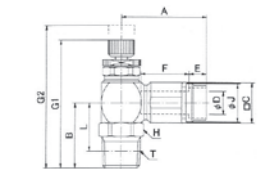

Model	A	B	φC	Tube O.D. φD	Outer Depth E	Inner Depth F	G1	G2	Spanner Flats H	φJ	L	Thread T
6-M5SC-O-H	15.5						35.7	38.9	12.0		12.5	M5 X 0.8
6-01SC-O-H	27.5	19.0	12.0	6.0	6.0	16.1	39.2	42.4	12.0	11.5	15.0	R1/8
6-02SC-O-H		22.0					42.2	45.4	14.0		16.0	R1/4
8-01SC-O-H		20.0					41.9	46.9	14.0		16.0	R1/8
8-02SC-O-H	29.5	23.0	14.0	8.0	6.0	16.8	44.9	49.9	14.0	13.5	17.0	R1/4
8-03SC-O-H		24.0					45.9	50.9	17.0		17.6	R3/8
10-02SC-O-H	33.4	24.5	17.0	10.0	7.0	17.6	48.7	54.7	17.0	16.5	18.5	R1/4
10-03SC-O-H		25.5					49.7	55.7	17.0		19.1	R3/8

*) Tube O.D φ12 is not standard stock item. Please ask the delivery schedule to your local distributor.

β Type

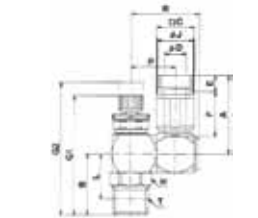

Model	A	B	φC	Tube O.D. φD	Outer Depth E	Inner Depth F	G1	G2	Spanner Flats H	φJ	L	P	R	Thread T
B6-M5SC-O-H	15.5						35.7	38.9	12.0		12.5			M5 X 0.8
B6-01SC-O-H	27.5	19.0	12.0	6.0	6.0	16.1	39.2	42.4	12.0	11.5	15.0	14.0	22.0	R1/8
B6-02SC-O-H		22.0					42.2	45.4	14.0		16.0			R1/4
B8-01SC-O-H		20.0					41.9	46.9	14.0		16.0			R1/8
B8-02SC-O-H	29.5	23.0	14.0	8.0	6.0	16.8	44.9	49.9	14.0	13.5	17.0	16.5	25.5	R1/4
B8-03SC-O-H		24.0					45.9	50.9	17.0		17.6			R3/8
B10-02SC-O-H	33.4	24.5	17.0	10.0	7.0	17.6	48.7	54.7	17.0	16.5	18.5	20.2	30.9	R1/4
B10-03SC-O-H		25.5					49.7	55.7	17.0		19.1			R3/8

*) Tube O.D φ12 is not standard stock item. Please ask the delivery schedule to your local distributor.

TUBE & BALANCER

สายยาง "ชิโยดะ" ผลิตจากเนื้อวัสดุโพลียูเรเทน น้ำหนักเบา ทนทาน ไม้รั่วซึมง่าย เหมาะสำหรับใช้กับงานลมทุกประเภท มีหลายสีหลายขนาดให้เลือก นอกจากนี้ยังมีสายยางทนสะเก็ดไฟ, สายใช้งานน้ำสำหรับงานแม่พิมพ์ ฯลฯ

TUBING FOR PNEUMATIC COMPONENTS

HYDROLYSIS RESISTANT POLYURETHANE TUBING



Specifications

Media	Compressed Air-Water
Working Temp. Range	-5~60 °C • 0~40 °C
Max. Burst Pressure	3MPa
Max. Working Pressure	0.8MPa
Working Vacuum Pressure	-100kPa

Recommended Fittings

- Touch Connector Five
- Touch Connector Mini
- Touch Connector "Fuji"
- Touch Connector
- Sleeve Connector
- Hose Fitting

*The value at a temperature of 20 °C(68 °F)

Main Features

- Hydrolysis resistant polyurethane tubing.
- Excellent flexibility. Softer than nylon tube and with rubber-like elasticity so bending radius is extremely small, thus, fatigue resistance to bending is very great.
- Superior mechanical strength and excellent abrasive resistance.
- Superior heat and cold resistance.
- Light Weight.
- Excellent tolerance.

Model	O.D. x I.D. (mm)	Burst Pressure (MPa)	Working Temperature (°C)	Min.Turning Radius (mm)	Tolerance (mm)	Weight (kg/m)	Color
TE-4x2.5	4x2.5	3	Compressed Air -5~60 Water 0~40	5	±0.1	0.009	BK LB W C Y LG R CBL G OR
TE-6	6x4			12		0.019	
TE-8	8x5			15		0.037	
TE-10	10x6.5			25		0.055	
TE-12	12x8			28		0.076	

BK=Black, W=White, Y=Yellow, R=Red, G=Green, LB=Light Blue, C=Transparent, LG=Light Green, CBL=Trans Blue

TUBE & BALANCER

สายยาง "ซีโยดะ" ผลิตจากเนื้อวัสดุโพลียูเรเทน น้ำหนักเบา ทนทาน ไม่รั่วซึมง่าย เหมาะสำหรับใช้กับงานลมทุกประเภท มีหลายสีหลายขนาดให้เลือก นอกจากนี้ยังมีสายยางทนสะเก็ดไฟ, สายใช้งานน้ำสำหรับงานแม่พิมพ์ ฯลฯ

TUBING FOR PNEUMATIC COMPONENTS

L-FLEX ANTI-SPATTER PUR TUBING



Main Features

- L-Flex is specially designed for Anti-spatter of welding machine. TE tube is covered by an olefinplastic (Flame Resistant type).
- L-Flex can be used for cooling water piping as well as pneumatic piping.
- Multi Core type are available upon request.
- Superior mechanical strength and excellent abrasive resistance.
- Superior heat and cold resistance.
- Light weight compared with rubber hose.
- For peeling of outer Jacket, C-18 cover peeler is recommended.

Specifications

Media	Compressed Air-Vacuum-Water
Working Temp. Range	-5~60 °C (23~140 °F)
Max. Burst Pressure	3MPa
Max. Working Pressure	0.8MPa
Working Vacuum Pressure	-100kPa

Recommended Fittings

- Touch Connector Five
- Touch Connector H Type
- Sleeve Connector
- Hose Fitting

*Above specifications are for air application. For water application, The value at a temperature of 20 °C(68 °F)

Model	O.D. x I.O.D x I.D. (mm)	Min.Turning Radius (mm)	Weight (g/m)	Color
LE-6	8X6X4	15	50	BK, W, Y
LE-8	10X8X5	20	76	
LE-10	12X10X6.5	25	103	
LE-12	14X12X8	30	132	G, LB, R
TWIN L-FLEX				
*2-LE-6	8X6X4	15	100	BK, W, Y
*2-LE-8	10X8X5	20	152	
*2-LE-10	12X10X6.5	25	206	
*2-LE-12	14X12X8	30	264	G, LB, R
ALE TYPE				
ALE-6	8.2X6X4	60	53	BK, W, Y
ALE-8	10.2X8X5	80	80	
ALE-10	12.2X10X6.5	100	108	G, LB, R
ALE-12	14.2X12X8	120	140	

BK=Black, W=White, Y=Yellow, G=Green, LB=Light Blue, R=Red

TUBE & BALANCER

สายยาง "ซีโยดะ" ผลิตจากเนื้อวัสดุโพลียูเรเทน น้ำหนักเบา ทนทาน ไม่รั่วซึมง่าย เหมาะสำหรับใช้กับงานลมทุกประเภท มีหลายสีหลายขนาดให้เลือก นอกจากนี้ยังมีสายยางทนสะเก็ดไฟ, สายใช้งานน้ำสำหรับงานแม่พิมพ์ ฯลฯ

TUBING FOR PNEUMATIC COMPONENTS

TE-AF ANTI-SPATTER TUBING



Main Features

- TE-AF was developed for robotic welding applications where the tube is subjected to weld spatter. TE-AF can be connected with one-touch fittings without removing the outer jacket as with the LE series tubing.
- TE-AF is a Polyether base PUR material with of a special rubber material. The performance of this material complies with 94UL (Underwriters Laboratory) V0 specification. When weld spatter comes in contact with the protective jacket material, the rubber becomes carbonized.
- Can be used for cooling water line and air piping.
- Much more flexibility than Nylon tubing.

Specifications

Media	Compressed Air-Water
Working Temp. Range	-5~60 °C • 0~50 °C
Max. Burst Pressure	3MPa
Max. Working Pressure	0.8MPa • 0.3MPa
Working Vacuum Pressure	-100kPa
Anti-Flaming Character	: Oxygen index method 28 Equivalent of UL-94 V0

Operation Precautions

- This material will be carbonized when in contact with material over 500-degree C intermittent use. It is not intended for use a constant environment of weld spatters at these temperatures.
- Polyether base PUR is suitable for water applications and is hydrolysis resistant but this material is not suitable for treated water which contains chlorine.
- The Oxygen index method No. of this material is 28. Density of oxygen on atmospheric is approx. 20. There-fore, this numerical value shows that this material does not burn easily.
- The material was tested in accordance with the UL94 V0 specification at the material manufacturer's lab. While the performance of the material complies with the UL specification, it is not endorsed by UL.

Model	O.D. x I.D. (mm)	Tolerance (mm)	Min.Turning Radius (mm)	Color
TE-6-AF	6.0x4.0	±0.1	15	BK
TE-8-AF	8.0x5.0		20	Y
TE-10-AF	10.0x6.5		25	W
TE-12-AF	12.0x8.0	+0.1 -0.15	30	R
				G
				LB

BK=Black, Y=Yellow, W=White, R=Red, G=Green, LB=Light Blue

TUBE & BALANCER

สายยาง "ชิโยดา" ผลิตจากเนื้อวัสดุโพลียูเรเทน น้ำหนักเบา ทนทาน ไม่รั่วซึมง่าย เหมาะสำหรับใช้กับงานลมทุกประเภท มีหลายสีหลายขนาดให้เลือก นอกจากนี้ยังมีสายยางทนสะเก็ดไฟ, สายใช้งานน้ำสำหรับงานแม่พิมพ์ ฯลฯ

TUBING FOR PNEUMATIC COMPONENTS

SUPER HYDROLYSIS RESISTANT POLYURETHANE TUBING P-FLEX Series



Specifications

Media	Water
Working Temp. Range	0~80 °C (32~175 °F)
Max. Burst Pressure	3MPa
Max. Working Pressure	0.3MPa
Recommended fittings	Thyme push connector

Main Features

- Special Hydrolysis resistant polyurethane tube. Suitable for cooling water
- Excellent flexibility. Softer than nylon tube and with rubber-like elasticity so bending radius is extremely small, thus, fatigue resistance to bending is very great.
- Superior mechanical strength and excellent abrasive resistance.
- Superior heat and cold resistance.
- Oil resistance. Resistant to spindle oil, machine oil and other oils.
- Light Weight.
- Excellent tolerance.

Model	O.D. x I.D. (mm)	Burst Pressure (MPa)	Working Temperature (°C)	Min.Turning Radius (mm)	Tolerance (mm)	Weight (kg/m)	Color
8P	8x5	3	0~80°	15	+0.05 -0.2	0.037	CB CP
10P	10x6.5			25	+0.1 -0.2	0.055	
12P	12x8			28		0.076	

CB=Trans Blue, CP=Trans Pink

TUBE & BALANCER

สายยาง "ชิโยดา" ผลิตจากเนื้อวัสดุโพลียูเรเทน น้ำหนักเบา ทนทาน ไม่รั่วซึมง่าย เหมาะสำหรับใช้กับงานลมทุกประเภท มีหลายสีหลายขนาดให้เลือก นอกจากนี้ยังมีสายยางทนสะเก็ดไฟ, สายใช้งานน้ำสำหรับงานแม่พิมพ์ ฯลฯ

HOSE FOR AIR TOOLS

POLYURETHANE BRAIDED HOSE

Construction

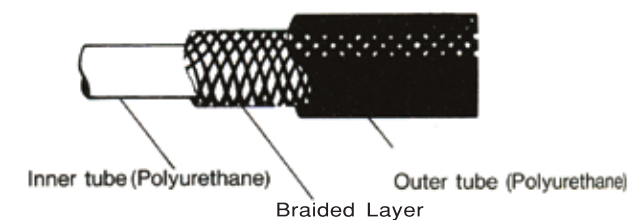

Specifications

Media	Compressed Air
Working Temp. Range	-5~60 °C (23~140 °F)
Max. Burst Pressure	6MPa
Max. Working Pressure	1.5MPa
Working Vacuum Pressure	-100kPa
Recommended fittings	Hose fitting

Specifications

Media	Compressed Air
Working Temp. Range	-5~60 °C (23~140 °F)
Max. Burst Pressure	9MPa
Max. Working Pressure	1.5MPa
Working Vacuum Pressure	-100kPa
Recommended fittings	Hose fitting

*The value at a temperature of 20 °C (68 °F)

Model	I.D. x O.D. (mm)	Burst Pressure (MPa)	Working Temperature (°C)	Min.Turning Radius (mm)	Tolerance (mm)	Weight (kg/m)	Color
AH-6	6x9	6	-5~60	45	± 0.2	0.045	OR
AH-6.5	6.5x10			50		0.055	
AH-8	8x12			60		0.076	
AH-11	11x16			80		0.132	
BH-6	6x9	6	-5~60	45	± 0.3	0.045	R
BH-6.5	6.5x10			50		0.055	
BH-8	8x12			60		0.076	
LH-6	6x9	6	-5~60	45	± 0.2	0.045	LG
LH-6.5	6.5x10			50		0.055	
LH-8	8x12			60		0.076	
ZH-6	6x9	9	-5~60	45	± 0.2	0.045	Y

OR=Orange, R=Red, LG=Light Green, Y=Yellow

TUBE & BALANCER

สายลมยาง CHYODA คุณภาพสูงจากญี่ปุ่น ผลิตจากเนื้อวัสดุ POLYURETHANE น้ำหนักเบา ทนทานต่อทุกสภาพการใช้งาน เหมาะสำหรับงานลม งานลากพื้นและงานน้ำ มีหลายสีหลายขนาดให้เลือกให้เหมาะกับการใช้งาน

ANTI-SPATTER BRAIDED HOSE GH

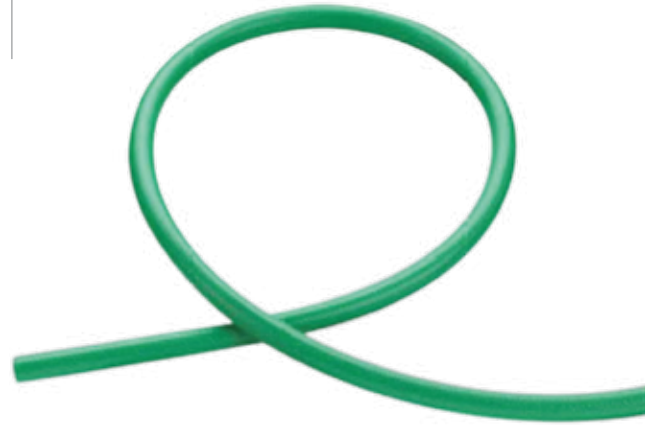

Main Features

- Spatter Resistant
Fire-proof material in the outside layer keeps tubes from being melted.
- Light Weight
Lighter than rubber hoses by 33%
- Easy Connection
No difficulty in connecting with Chiyoda connectors.

Specifications

Media	Compressed Air
Working Temperature Range	-5~60°C <23-140°F>
Max. Burst Pressure	6 MPa
Max. Working Pressure	1.5 MPa
Fitting used	Hose Fittings, Couplings

*The value at a temperature of 20°C (68°F)

Material : Polyurethane

Model	I.D.x O.D. (mm)	Min.Turning Radius (mm)	Tolerance (mm)	Weight (kg/m)	Color
GH-6.5	6.5 x 10	60	±0.2	0.055	G
GH-8	8 x 12	70		0.070	
GH-11	11 x 16	100		0.130	

*G (Green)

*(Real) : 10m • 20m • 30m • 50m • 100m

WATER-PROOF TYPE POLYURETHANE BRAIDED HOSE

Main Features

- Multi-use of Compressed Air and Industrial Water
Water-proof polyurethane enable you to use only one piping system for 2 different media of water and air.
- Flexible Material
Maintain flexibility even in cold district. The material keeps from tube kinkings.
- Easy Connection
Very easy to connect it to our general fittings.
- Environmentally Friendly Hose
No plasticizer in the material protects media from contamination. No environmental load substances are included.



Material : Polyurethane

Model	I.D.x O.D. (mm)	Tolerance (mm)	Min.Turning Radius (mm)	Weight (kg/m)	Color
FH-11	11 x 16	±0.3	80	0.130	LB
FH-16	16 x 21		90	0.175	W

* (Real) : 20m • 50m • 100m

LB (Light Blue)
W (White)

Specifications

Media	Compressed Air	Industrial water
Working Temperature Range	-5~60°C <23-140°F>	5~40°C <41-104°F>
Max. Burst Pressure	5 MPa	
Max. Working Pressure	1.0 MPa	0.3 MPa
Water hammer considered in value above		
Fitting used	Hose Fittings, Couplings	

*The value at a temperature of 20°C (68°F)

Please choose dedicated tubing when used industrial water.

TUBE & BALANCER

สายลมยาง CHYODA คุณภาพสูงจากญี่ปุ่น ผลิตจากเนื้อวัสดุ POLYURETHANE น้ำหนักเบา ทนทานต่อทุกสภาพการใช้งาน เหมาะสำหรับงานลม งานลากพื้นและงานน้ำ มีหลายสีหลายขนาดให้เลือกให้เหมาะกับการใช้งาน

SOFT POLYURETHANE BRAIDED HOSE

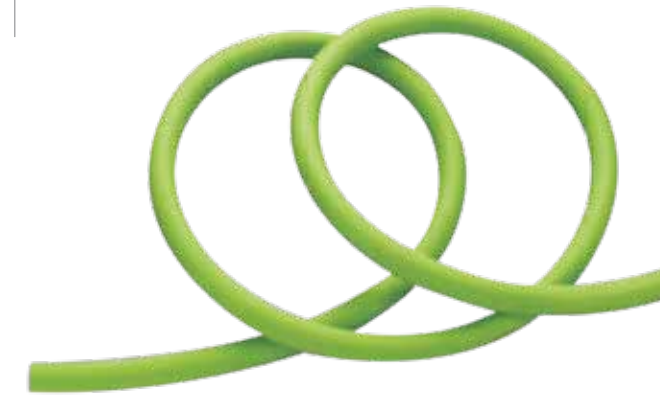

Main Features

- Flexibility
Easy use with excellent flexibility
- Unique Surface
Jagged surface keeps itself from kinking and sticking on a floor.

Specifications

Media	Compressed Air
Working Temperature Range	-5~60°C <23-140°F>
Max. Burst Pressure	5 MPa
Max. Working Pressure	1.0 MPa
Fitting used	Hose Fittings, Nut-Couplings

*The value at a temperature of 20°C (68°F)

Material : Polyurethane

Model	I.D.x O.D. (mm)	Tolerance (mm)	Min.Turning Radius (mm)	Weight (kg/m)	Color
DH-6.5	6.5 x 10	±0.2	40	0.06	LG
DH-8	8 x 12		45	0.08	
DH-11	11 x 16		65	0.14	

*(Real) : 10m • 20m • 30m • 50m • 100m
LG (Light Green)

LIGHT WEIGHT PUR BRAIDED HOSE

Main Features

- Nice Flexibility.
- Light weight (45% lighter than BH series).
- High Air Flow.
- High Pressure Resistance.
- NO kinking.
- Superior mechanical strength and excellent abrasive resistance.
- Superior heat and cold resistance.
- Oil resistance. Resistance to spindle oil, machine oil and other oil.



Material : Polyurethane

Specifications

Media	Compressed Air	Industrial water
Working Temperature Range	-5~60°C <23-140°F>	
Max. Burst Pressure	12 MPa	
Max. Working Pressure	1.5 MPa	-100 MPa
Water hammer considered in value above		
Fitting used	Mega-fitting, Mega-Coupling	

*The value at a temperature of 20°C (68°F)

* (Real)

MH-8...10, 20, 30, 100m
MH-10...10, 20, 30, 90m
LB (Light Blue)

Construction

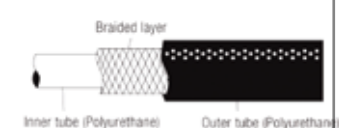

TUBE & BALANCER

สายยาง "ชิโยดะ" ผลิตจากเนื้อวัสดุโพลียูเรเทน น้ำหนักเบา ทนทาน ไม้รั่วซึมง่าย เหมาะสำหรับใช้กับงานลมทุกประเภท มีหลายสีหลายขนาดให้เลือก นอกจากนี้ยังมีสายยางทนสะเก็ดไฟ, สายใช้งานน้ำสำหรับงานแม่พิมพ์ ฯลฯ

TUBING FOR PNEUMATIC COMPONENTS

POLYURETHANE SPIRAL TUBING TPS SERIES



Specifications

Media	Compressed Air·Water
Working Temp. Range	-5~60 °C · 0~40 °C
Max. Bust Pressure	3MPa
Max. Working Pressure	0.8MPa·0.3MPa
Working Vacuum Pressure	-100kPa

Recommended Fittings

- Touch Connector Five ● Touch Connector Mini
- Touch Connector "Fuji" ● Touch Connector
- Sleeve Connector ● Hose Fittings

*The value at a temperature of 20 °C (68 °F)

Main Features

- TPS series is a coiled version of TP tube. It is suitable for the piping of movable part. A small spiral diameter is completed in a small space without distorting the joints.
- Excellent flexibility. Softer than nylon tube and with rubber-like elasticity so bending radius is extremely small, thus, fatigue resistance to bending is very great.
- Superior mechanical strength and excellent abrasive resistance.
- Superior heat and cold resistance.
- Oil resistance. Resistant to spindle oil, machine oil and other oils.
- Light weight
- Custom size and materials are available.

Operation Precautions

- Do not use knives or scissors to cut the tubing. As exact cross section is critical to performance, please use our tube cutter.
- TPS Series designed for using as pneumatic piping. We do not recommend you to use TPS Series for other media. If you would like to use TPS Series for other media, the user assumes all risk and liabilities.
- If you have any question, please contact your local distributor.

TUBE & BALANCER

สายยาง "ชิโยดะ" ผลิตจากเนื้อวัสดุโพลียูเรเทน น้ำหนักเบา ทนทาน ไม้รั่วซึมง่าย เหมาะสำหรับใช้กับงานลมทุกประเภท มีหลายสีหลายขนาดให้เลือก นอกจากนี้ยังมีสายยางทนสะเก็ดไฟ, สายใช้งานน้ำสำหรับงานแม่พิมพ์ ฯลฯ

TUBING FOR PNEUMATIC COMPONENTS

POLYURETHANE SPIRAL TUBING TPS SERIES

TPS-8-30

Polyurethane Tube O.D (mm) No. of turns

Model	Tube Used	Service Length (mm)	A (mm)	B (mm)	C (mm)	ØD (mm)	Model	Tube Used	Service Length (mm)	A (mm)	B (mm)	C (mm)	ØD (mm)
* TPS-4-5	TE-4	500	420	20	200	21	* TPS-8-5	TE-8	600	440	40	200	42
* TPS-4-10	TE-4	600	440	40	200	21	* TPS-8-10	TE-8	800	480	80	200	42
TPS-4-15	TE-4	700	460	60	200	21	TPS-8-15	TE-8	1,000	520	120	200	42
* TPS-4-20	TE-4	800	480	80	200	21	* TPS-8-20	TE-8	1,200	560	160	200	42
* TPS-4-25	TE-4	900	500	100	200	21	* TPS-8-25	TE-8	1,400	600	200	200	42
TPS-4-30	TE-4	1,000	520	120	200	21	TPS-8-30	TE-8	1,600	640	240	200	42
* TPS-4-35	TE-4	1,100	540	140	200	21	* TPS-8-35	TE-8	1,800	680	280	200	42
* TPS-4-40	TE-4	1,200	560	160	200	21	* TPS-8-40	TE-8	2,000	720	320	200	42
TPS-4-45	TE-4	1,300	580	180	200	21	TPS-8-45	TE-8	2,200	760	360	200	42
* TPS-4-50	TE-4	1,400	600	200	200	21	* TPS-8-50	TE-8	2,400	800	400	200	42
* TPS-4-55	TE-4	1,500	620	220	200	21	* TPS-8-55	TE-8	2,600	840	440	200	42
* TPS-4-60	TE-4	1,600	640	240	200	21	* TPS-8-60	TE-8	2,800	880	480	200	42
* TPS-6-5	TE-6	550	430	30	200	38	* TPS-10-5	TE-10	650	450	50	200	52
* TPS-6-10	TE-6	700	460	60	200	38	* TPS-10-10	TE-10	900	500	100	200	52
TPS-6-15	TE-6	850	490	90	200	38	TPS-10-15	TE-10	1,150	550	150	200	52
* TPS-6-20	TE-6	1,000	520	120	200	38	* TPS-10-20	TE-10	1,400	600	200	200	52
* TPS-6-25	TE-6	1,150	550	150	200	38	* TPS-10-25	TE-10	1,650	650	250	200	52
TPS-6-30	TE-6	1,300	580	180	200	38	TPS-10-30	TE-10	1,900	700	300	200	52
* TPS-6-35	TE-6	1,450	610	210	200	38	* TPS-10-35	TE-10	2,150	750	350	200	52
* TPS-6-40	TE-6	1,600	640	240	200	38	* TPS-10-40	TE-10	2,400	800	400	200	52
TPS-6-45	TE-6	1,750	670	270	200	38	TPS-10-45	TE-10	2,650	850	450	200	52
* TPS-6-50	TE-6	1,900	700	300	200	38	* TPS-10-50	TE-10	2,900	900	500	200	52
* TPS-6-55	TE-6	2,050	730	330	200	38	* TPS-10-55	TE-10	3,150	950	550	200	52
* TPS-6-60	TE-6	2,200	760	360	200	38	* TPS-10-60	TE-10	3,400	1,000	600	200	52
* TPS-12-5	TE-12	700	460	60	200	67							
* TPS-12-10	TE-12	1,000	520	120	200	67							
TPS-12-15	TE-12	1,300	580	180	200	67							
* TPS-12-20	TE-12	1,600	640	240	200	67							
* TPS-12-25	TE-12	1,900	700	300	200	67							
TPS-12-30	TE-12	2,200	760	360	200	67							
* TPS-12-35	TE-12	2,500	820	420	200	67							
* TPS-12-40	TE-12	2,800	880	480	200	67							
TPS-12-45	TE-12	3,100	940	540	200	67							
* TPS-12-50	TE-12	3,400	1,000	600	200	67							
* TPS-12-55	TE-12	3,700	1,060	660	200	67							

Dimensions

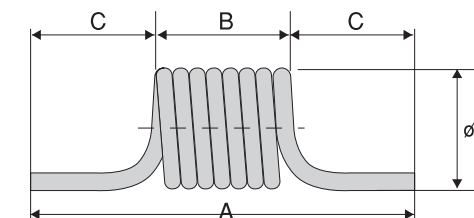

*marked items are not standard stock items. Please ask the delivery schedule to your local distributor.

TUBE & BALANCER

สายยาง "จิโยดะ" ผลิตจากเนื้อวัสดุโพลียูเรเทน น้ำหนักเบา ทนทาน ไม้รั่วซึมง่าย เหมาะสำหรับใช้กับงานลมทุกประเภท มีหลายสีหลายขนาดให้เลือก นอกจากนี้ยังมีสายยางทนสะเก็ดไฟ, สายใช้งานน้ำสำหรับงานแม่พิมพ์ ฯลฯ

TUBING FOR PNEUMATIC COMPONENTS

MULTI SPIRAL POLYURETHANE TUBING

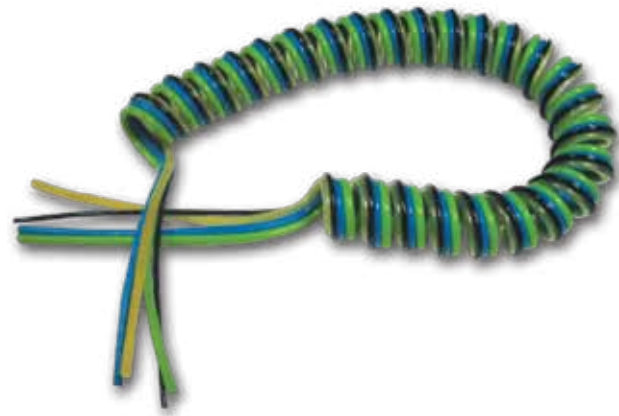

Specifications

Media	Compressed Air
Working Temp. Range	-5~60 °C (23~140 °F)
Max. Bust Pressure	3MPa
Max. Working Pressure	0.8MPa
Working Vacuum Pressure	-100kPa

Recommended fittings

- Touch connector Five
- Touch connector Mini
- Touch connector "Fuji"
- Touch connector
- Sleeve Connector
- Hose fitting

*The value at a temperature of 20 °C (68 °F)

Main Features

- Multi-Spiral tube is made by bonding TP tube. It is Suitable for centralized piping in expanding parts. Also it is suitable for moving and expanding parts of pneumatic components.
- Easily to separated and arranged as desired.
- Excellent flexibility. Softer than nylon tube and with rubber-like elasticity so bending radius is extremely small, thus, fatigue resistance to bending is very great.
- Superior mechanical strength and excellent abrasive resistance.
- Superior heat and cold resistance.
- Oil resistance. Resistant to spindle oil, machine oil and other oils. Light Weight.

Operation Precautions

- Do not use knives or scissors to cut the tubing. As exact cross section is critical to performance, please use our tube cutter.
- MTP tubing was designed for using as pneumatic piping. We do not recommend you to use MTP for other media. If you would like to use MTP for other media, the user assumes all risk and liabilities.
- If you have any question, please contact your local distributor.

TUBE & BALANCER

สายยาง "จิโยดะ" ผลิตจากเนื้อวัสดุโพลียูเรเทน น้ำหนักเบา ทนทาน ไม้รั่วซึมง่าย เหมาะสำหรับใช้กับงานลมทุกประเภท มีหลายสีหลายขนาดให้เลือก นอกจากนี้ยังมีสายยางทนสะเก็ดไฟ, สายใช้งานน้ำสำหรับงานแม่พิมพ์ ฯลฯ

TUBING FOR PNEUMATIC COMPONENTS

MULTI SPIRAL POLYURETHANE TUBING



Dimensions

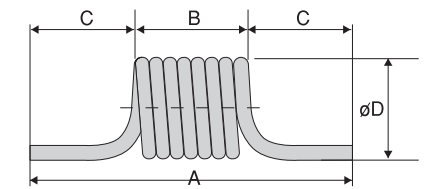

Model	Tube Used	Service Length	A	B	C	ØD
2-MPS-4-5S	TP-4	529	443	43	200	21
2-MPS-4-10S	TP-4	658	486	86	200	21
2-MPS-4-15S	TP-4	787	529	129	200	21
2-MPS-4-20S	TP-4	916	579	172	200	21
* 2-MPS-4-25S	TP-4	1,045	615	215	200	21
* 2-MPS-4-30S	TP-4	1,174	658	258	200	21
* 2-MPS-4-35S	TP-4	1,303	701	301	200	21
* 2-MPS-4-40S	TP-4	1,432	744	344	200	21
* 2-MPS-4-45S	TP-4	1,561	784	387	200	21
* 2-MPS-4-50S	TP-4	1,690	830	430	200	21
2-MPS-6-5S	TP-6	595	465	65	200	38
2-MPS-6-10S	TP-6	790	530	130	200	38
2-MPS-6-15S	TP-6	985	595	195	200	38
2-MPS-6-20S	TP-6	1,180	660	260	200	38
* 2-MPS-6-25S	TP-6	1,375	725	325	200	38
* 2-MPS-6-30S	TP-6	1,570	790	390	200	38
* 2-MPS-6-35S	TP-6	1,765	855	455	200	38
* 2-MPS-6-40S	TP-6	1,960	920	520	200	38
* 2-MPS-6-45S	TP-6	2,155	985	585	200	38
* 2-MPS-8-5S	TP-8	670	490	90	200	42
* 2-MPS-8-10S	TP-8	940	580	180	200	42
* 2-MPS-8-15S	TP-8	1,210	670	270	200	42
* 2-MPS-8-20S	TP-8	1,480	760	360	200	42
* 2-MPS-8-25S	TP-8	1,750	850	450	200	42
* 2-MPS-8-30S	TP-8	2,020	940	540	200	42
* 2-MPS-8-35S	TP-8	2,290	1,030	630	200	42
* 2-MPS-8-40S	TP-8	2,560	1,120	720	200	42
* 2-MPS-8-45S	TP-8	2,830	1,210	810	200	42
* 2-MPS-10-5S	TP-10	739	513	113	200	52
* 2-MPS-10-10S	TP-10	1,078	626	226	200	52
* 2-MPS-10-15S	TP-10	1,417	739	339	200	52
* 2-MPS-10-20S	TP-10	1,756	852	452	200	52
* 2-MPS-10-25S	TP-10	2,095	965	565	200	52
* 2-MPS-10-30S	TP-10	2,434	1,078	678	200	52
* 2-MPS-12-5S	TP-12	805	535	135	200	67
* 2-MPS-12-10S	TP-12	1,210	670	270	200	67
* 2-MPS-12-15S	TP-12	1,715	805	405	200	67
* 2-MPS-12-20S	TP-12	2,020	940	540	200	67
* 2-MPS-12-25S	TP-12	2,425	1,075	675	200	67

Model	Tube Used	Service Length	A	B	C	ØD
* 3-MPS-4-5S	TP-4	563	465	65	200	27
* 3-MPS-4-10S	TP-4	723	529	129	200	27
* 3-MPS-4-15S	TP-4	885	594	194	200	27
* 3-MPS-4-20S	TP-4	1,045	658	258	200	27
* 3-MPS-4-25S	TP-4	1,208	723	323	200	27
* 3-MPS-4-30S	TP-4	1,368	787	387	200	27
* 3-MPS-4-35S	TP-4	1,530	852	452	200	27
* 3-MPS-4-40S	TP-4	1,690	916	516	200	27
* 3-MPS-4-45S	TP-4	1,853	981	581	200	27
* 3-MPS-6-5S	TP-6	645	498	98	200	44
* 3-MPS-6-10S	TP-6	888	595	195	200	44
* 3-MPS-6-15S	TP-6	1,133	693	293	200	44
* 3-MPS-6-20S	TP-6	1,375	790	390	200	44
* 3-MPS-6-25S	TP-6	1,620	888	488	200	44
* 3-MPS-6-30S	TP-6	1,863	985	585	200	44
* 3-MPS-6-35S	TP-6	2,108	1,083	683	200	44
* 3-MPS-6-40S	TP-6	2,350	1,180	780	200	44
* 3-MPS-8-5S	TP-8	738	535	135	200	50
* 3-MPS-8-10S	TP-8	1,075	670	270	200	50
* 3-MPS-8-15S	TP-8	1,413	805	405	200	50
* 3-MPS-8-20S	TP-8	1,750	940	540	200	50
* 3-MPS-8-25S	TP-8	2,088	1,075	675	200	50
* 3-MPS-10-5S	TP-10	825	570	170	200	63
* 3-MPS-10-10S	TP-10	1,248	739	339	200	63
* 3-MPS-10-15S	TP-10	1,673	909	509	200	63
* 3-MPS-10-20S	TP-10	2,095	1,078	678	200	63
* 3-MPS-12-5S	TP-12	908	603	203	200	84
* 3-MPS-12-10S	TP-12	1,413	805	405	200	84
* 3-MPS-12-15S	TP-12	1,920	1,008	608	200	84
* 4-MPS-4-5S	TP-4	529	443	43	200	35
* 4-MPS-4-10S	TP-4	658	486	86	200	35
* 4-MPS-4-15S	TP-4	787	529	129	200	35
* 4-MPS-4-20S	TP-4	916	572	172	200	35
* 4-MPS-4-25S	TP-4	1,045	615	215	200	35
* 4-MPS-4-30S	TP-4	1,174	658	258	200	35
* 4-MPS-4-35S	TP-4	1,303	701	301	200	35
* 4-MPS-4-40S	TP-4	1,432	744	344	200	35
* 4-MPS-4-45S	TP-4	1,560	787	387	200	35

*marked items are not standard stock items. Please ask the delivery schedule to your local distributor.

TUBE & BALANCER

สายยาง "ชิโยดา" ผลิตจากเนื้อวัสดุโพลียูเรเทน น้ำหนักเบา ทนทาน ไม้รั่วซึมง่าย เหมาะสำหรับใช้กับงานลมทุกประเภท มีหลายสีหลายขนาดให้เลือก นอกจากนี้ยังมีสายยางทนสะเก็ดไฟ, สายใช้งานน้ำสำหรับงานแม่พิมพ์ ฯลฯ

TUBING FOR PNEUMATIC COMPONENTS

MULTI SPIRAL POLYURETHANE TUBING

3-MPS-4-5S

Core Multi Spiral-Polyurethane Tubing Tube O.D (mm) No. of turns Standard color

Dimensions

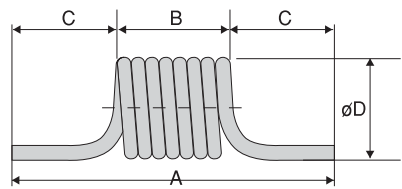

Model	Tube Used	Service Length	A	B	C	ØD
*4-MPS-6-5S	TP-6	595	465	65	200	56
*4-MPS-6-10S	TP-6	790	530	130	200	56
*4-MPS-6-15S	TP-6	985	595	195	200	56
*4-MPS-6-20S	TP-6	1,180	660	260	200	56
*4-MPS-6-25S	TP-6	1,375	725	325	200	56
*4-MPS-6-30S	TP-6	1,570	790	390	200	56
*4-MPS-6-35S	TP-6	1,765	855	455	200	56
*4-MPS-6-40S	TP-6	1,960	920	520	200	56
*4-MPS-6-45S	TP-6	2,155	985	585	200	56
*4-MPS-8-5S	TP-8	670	490	90	200	66
*4-MPS-8-10S	TP-8	940	580	180	200	66
*4-MPS-8-15S	TP-8	1,210	670	270	200	66
*4-MPS-8-20S	TP-8	1,480	760	360	200	66
*4-MPS-8-25S	TP-8	1,750	850	450	200	66
*4-MPS-8-30S	TP-8	2,020	940	540	200	66
*4-MPS-8-35S	TP-8	2,290	1,030	630	200	66
*4-MPS-8-40S	TP-8	2,560	1,120	720	200	66
*4-MPS-8-45S	TP-8	2,830	1,210	810	200	66
*4-MPS-10-5S	TP-10	739	513	113	200	83
*4-MPS-10-10S	TP-10	1,078	626	226	200	83
*4-MPS-10-15S	TP-10	1,417	739	339	200	83
*4-MPS-10-20S	TP-10	1,756	852	452	200	83
*4-MPS-10-25S	TP-10	2,095	965	565	200	83
*4-MPS-10-30S	TP-10	2,434	1,078	678	200	83
*4-MPS-12-5S	TP-12	805	535	135	200	108
*4-MPS-12-10S	TP-12	1,210	670	270	200	108
*4-MPS-12-15S	TP-12	1,615	805	405	200	108
*4-MPS-12-20S	TP-12	2,020	940	540	200	108
*4-MPS-12-25S	TP-12	2,425	1,075	675	200	108
*5-MPS-4-5S	TP-4	563	465	65	200	34
*5-MPS-4-10S	TP-4	723	529	129	200	34
*5-MPS-4-15S	TP-4	885	594	194	200	34
*5-MPS-4-20S	TP-4	1,045	658	258	200	34
*5-MPS-4-25S	TP-4	1,208	723	323	200	34
*5-MPS-4-30S	TP-4	1,368	787	387	200	34
*5-MPS-4-35S	TP-4	1,530	852	452	200	34
*5-MPS-4-40S	TP-4	1,690	916	516	200	34
*5-MPS-4-45S	TP-4	1,853	981	581	200	34

Model	Tube Used	Service Length	A	B	C	ØD
*5-MPS-6-5S	TP-6	645	498	98	200	56
*5-MPS-6-10S	TP-6	888	595	195	200	56
*5-MPS-6-15S	TP-6	1,133	693	293	200	56
*5-MPS-6-20S	TP-6	1,375	790	390	200	56
*5-MPS-6-25S	TP-6	1,620	888	488	200	56
*5-MPS-6-30S	TP-6	1,863	985	585	200	56
*5-MPS-6-35S	TP-6	2,108	1,083	683	200	56
*5-MPS-6-40S	TP-6	2,350	1,180	780	200	56
*5-MPS-8-5S	TP-8	738	535	135	200	73
*5-MPS-8-10S	TP-8	1,075	670	270	200	73
*5-MPS-8-15S	TP-8	1,413	805	405	200	73
*5-MPS-8-20S	TP-8	1,750	940	540	200	73
*5-MPS-8-25S	TP-8	2,088	1,075	675	200	73
*5-MPS-10-5S	TP-10	825	570	170	200	97
*5-MPS-10-10S	TP-10	1,248	739	339	200	97
*5-MPS-10-15S	TP-10	1,673	909	509	200	97
*5-MPS-10-20S	TP-10	2,095	1,078	678	200	97
*5-MPS-12-5S	TP-12	908	603	203	200	121
*5-MPS-12-10S	TP-12	1,413	805	405	200	121
*5-MPS-12-15S	TP-12	1,920	1,008	608	200	121
*6-MPS-4-5S	TP-4	563	465	65	200	35
*6-MPS-4-10S	TP-4	723	529	129	200	35
*6-MPS-4-15S	TP-4	885	594	194	200	35
*6-MPS-4-20S	TP-4	1,045	658	258	200	35
*6-MPS-4-25S	TP-4	1,208	723	323	200	35
*6-MPS-4-30S	TP-4	1,368	787	387	200	35
*6-MPS-4-35S	TP-4	1,530	852	452	200	35
*6-MPS-4-40S	TP-4	1,690	916	516	200	35
*6-MPS-4-45S	TP-4	1,853	981	581	200	35
*6-MPS-6-5S	TP-6	645	498	98	200	58
*6-MPS-6-10S	TP-6	888	595	195	200	58
*6-MPS-6-15S	TP-6	1,133	693	293	200	58
*6-MPS-6-20S	TP-6	1,375	790	390	200	58
*6-MPS-6-25S	TP-6	1,620	888	488	200	58
*6-MPS-6-30S	TP-6	1,863	985	585	200	58
*6-MPS-6-35S	TP-6	2,108	1,083	683	200	58
*6-MPS-6-40S	TP-6	2,350	1,180	780	200	58

*marked items are not standard stock items. Please ask the delivery schedule to your local distributor.

TUBE & BALANCER

สายยาง "ชิโยดา" ผลิตจากเนื้อวัสดุโพลียูเรเทน น้ำหนักเบา ทนทาน ไม้รั่วซึมง่าย เหมาะสำหรับใช้กับงานลมทุกประเภท มีหลายสีหลายขนาดให้เลือก นอกจากนี้ยังมีสายยางทนสะเก็ดไฟ, สายใช้งานน้ำสำหรับงานแม่พิมพ์ ฯลฯ

TUBING FOR PNEUMATIC COMPONENTS

MULTI SPIRAL POLYURETHANE TUBING

3-MPS-4-5S

Core Multi Spiral-Polyurethane Tubing Tube O.D (mm) No. of turns Standard color

Dimensions

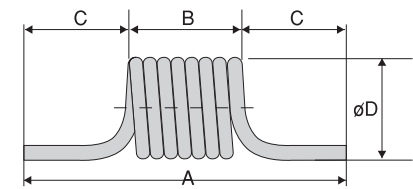

Model	Tube Used	Service Length	A	B	C	ØD
*6-MPS-8-5S	TP-8	738	535	135	200	75
*6-MPS-8-10S	TP-8	1,075	670	270	200	75
*6-MPS-8-15S	TP-8	1,413	805	405	200	75
*6-MPS-8-20S	TP-8	1,750	940	540	200	75
*6-MPS-8-25S	TP-8	2,088	1,075	675	200	75
*6-MPS-10-5S	TP-10	825	570	170	200	100
*6-MPS-10-10S	TP-10	1,248	739	339	200	100
*6-MPS-10-15S	TP-10	1,673	909	509	200	100
*6-MPS-10-20S	TP-10	2,095	1,078	678	200	100
*6-MPS-12-5S	TP-12	908	603	203	200	124
*6-MPS-12-10S	TP-12	1,413	805	405	200	124
*4-MPS-12-15S	TP-12	1,920	1,008	608	200	124
*7-MPS-4-5S	TP-4	572	486	86	200	41
*7-MPS-4-10S	TP-4	744	572	172	200	41
*7-MPS-4-15S	TP-4	916	658	258	200	41
*7-MPS-4-20S	TP-4	1,088	744	344	200	41
*7-MPS-4-25S	TP-4	1,260	830	430	200	41
*7-MPS-4-30S	TP-4	1,432	916	516	200	41
*7-MPS-4-35S	TP-4	1,604	1,002	602	200	41
*7-MPS-4-40S	TP-4	1,776	1,088	688	200	41
*7-MPS-4-45S	TP-4	1,948	1,174	774	200	41
*7-MPS-6-5S	TP-6	660	530	130	200	65
*7-MPS-6-10S	TP-6	920	660	260	200	65
*7-MPS-6-15S	TP-6	1,180	790	390	200	65
*7-MPS-6-20S	TP-6	1,440	920	520	200	65
*7-MPS-6-25S	TP-6	1,700	1,050	650	200	65
*7-MPS-6-30S	TP-6	1,960	1,180	780	200	65
*7-MPS-8-5S	TP-8	760	580	180	200	90
*7-MPS-8-10S	TP-8	1,120	760	360	200	90
*7-MPS-8-15S	TP-8	1,480	940	540	200	90
*7-MPS-8-20S	TP-8	1,840	1,120	720	200	90
*7-MPS-10-5S	TP-10	852	626	226	200	113
*7-MPS-10-10S	TP-10	1,304	852	452	200	113
*7-MPS-10-15S	TP-10	1,756	1,078	678	200	113
*7-MPS-12-5S	TP-12	940	670	270	200	145
*7-MPS-12-10S	TP-12	1,480	940	540	200	145
*7-MPS-12-15S	TP-12	1,912	1,156	756	200	145

Model	Tube Used	Service Length	A	B	C	ØD
*8-MPS-4-5S	TP-4	572	486	86	200	42
*8-MPS-4-10S	TP-4	744	572	172	200	42
*8-MPS-4-15S	TP-4	916	658	258	200	42
*8-MPS-4-20S	TP-4	1,088	744	344	200	42
*8-MPS-4-25S	TP-4	1,260	830	430	200	42
*8-MPS-4-30S	TP-4	1,432	916	516	200	42
*8-MPS-4-35S	TP-4	1,604	1,002	602	200	42
*8-MPS-4-40S	TP-4	1,776	1,088	688	200	42
*8-MPS-4-45S	TP-4	1,948	1,174	774	200	42
*8-MPS-6-5S	TP-6	660	530	130	200	67
*8-MPS-6-10S	TP-6	920	660	260	200	67
*8-MPS-6-15S	TP-6	1,180	790	390	200	67
*8-MPS-6-20S	TP-6	1,440	920	520	200	67
*8-MPS-6-25S	TP-6	1,700	1,050	650	200	67
*8-MPS-6-30S	TP-6	1,960	1,180	780	200	67
*8-MPS-8-5S	TP-8	760	580	180	200	92
*8-MPS-8-10S	TP-8	1,120	760	360	200	92
*8-MPS-8-15S	TP-8	1,480	940	540	200	92
*8-MPS-8-20S	TP-8	1,840	1,120	720	200	92
*8-MPS-10-5S	TP-10	852	626	226	200	116
*8-MPS-10-10S	TP-10	1,304	852	452	200	116
*8-MPS-10-15S	TP-10	1,756	1,078	678	200	116
*8-MPS-12-5S	TP-12	940	670	270	200	148
*8-MPS-12-10S	TP-12	1,480	940	540	200	148
*8-MPS-12-15S	TP-12	1,912	1,156	756	200	148

The dimensions will vary slightly from the chart above due to the character of the material.

*marked items are not standard stock items. Please ask the delivery schedule to your local distributor.

TUBE & BALANCER

สายยาง "ชิโยดา" ผลิตจากเนื้อวัสดุโพลียูเรเทน น้ำหนักเบา ทนทาน ไม่รั่วซึมง่าย เหมาะสำหรับใช้กับงานลมทุกประเภท มีหลายสีหลายขนาดให้เลือก นอกจากนี้ยังมีสายยางทนสะเก็ดไฟ, สายใช้งานน้ำสำหรับงานแม่พิมพ์ ฯลฯ

HOSE FOR AIR TOOLS

SPIRAL AIR HOSE

Dimensions

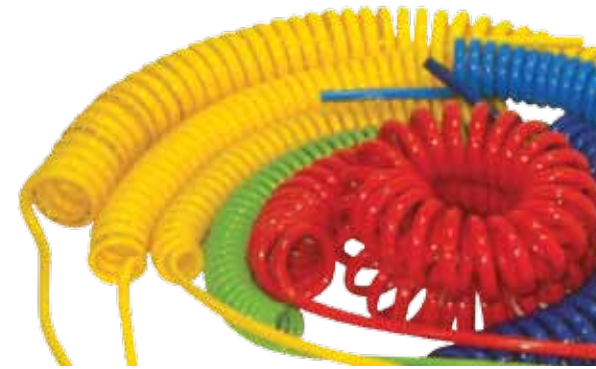
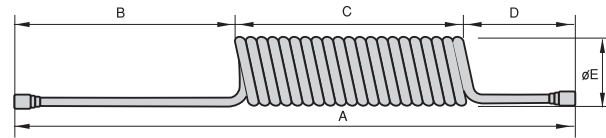

Main Features

- Excellent flexibility. Softer than nylon tube and excellent in restorability to original shape.
- Superior mechanical strength and excellent abrasive resistance.
- Superior heat and cold resistance.
- Oil resistance.
- Light Weight.

Specifications

Media	Compressed Air
Working Temp. Range	-5~60 °C (23~140 °F)
Max. Burst Pressure	3MPa
Max. Working Pressure	0.8MPa
Recommended fittings	Hose Fitting

*The value at a temperature of 20 °C (68 °F)
*Custom size and color are available as custom model.

Model	Hose Size I.D.xO.D.	Service Length (mm)	Hose Length (mm)	A (mm)	B (mm)	C (mm)	D (mm)	E (mm)	Standard Fittings	Weight (g)
TPS-803-0105Y	5x8	2,000	2,500	780	500	180	100	42	G1/4	190
TPS-805-0105Y	5x8	4,000	5,000	1,000	500	400	100	42	G1/4	280
TPS-808-0105Y	5x8	6,000	7,500	1,230	500	630	100	42	G1/4	370
TPS-810-0105Y	5x8	8,000	10,000	1,400	500	800	100	42	G1/4	460
TPS-1003-0105Y	6.5x10	2,000	2,500	785	500	185	100	52	G1/4	230
TPS-1005-0105Y	6.5x10	4,000	5,000	1,000	500	400	100	52	G1/4	360
TPS-1008-0105Y	6.5x10	6,000	7,500	1,235	500	635	100	52	G1/4	500
TPS-1010-0105Y	6.5x10	8,000	10,000	1,400	500	800	100	52	G1/4	630
TPS-1203-0105Y	8x12	2,000	2,500	780	500	180	100	65	G1/4	320
TPS-1205-0105Y	8x12	4,000	5,000	990	500	390	100	65	G1/4	510
TPS-1208-0105Y	8x12	6,000	7,500	1,190	500	590	100	65	G1/4	700
TPS-1210-0105Y	8x12	8,000	10,000	1,380	500	780	100	65	G1/4	880
TPS-1603-0105Y	11x16	2,000	2,500	720	500	120	100	108	Rc1/2	580
TPS-1605-0105Y	11x16	4,000	5,000	840	500	240	100	108	Rc1/2	900
TPS-1608-0105Y	11x16	6,000	7,500	1,000	500	400	100	108	Rc1/2	1200
TPS-1610-0105Y	11x16	8,000	10,000	1,170	500	570	100	108	Rc1/2	1500

TUBE & BALANCER

เพิ่มความสะดวกยิ่งกว่าบาลานเซอร์แบบธรรมดา คือ นอกจากจะแขวนเครื่องมือแล้วยังเป็นสายลมในตัว ซึ่งต่อเข้ากับเครื่องมือได้ ทำจากอลูมิเนียม แข็งแรงทนทาน สามารถปรับแรงดึงที่ตัวเครื่อง โดยไม่ต้องใช้เครื่องมือใดๆ เหมาะสำหรับโรงงานประกอบต่างๆ

MEGAHOSE BALANCER

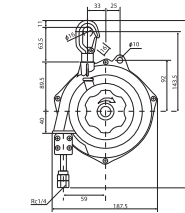
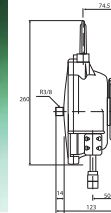

Main Features

- The new Megahose Balancer generates the maximum performance of pneumatic tools due to the newly designed 8x10.5mm polyurethane braided hose. This provides much increased air flow.
- The new Megahose Balancer has a dial type torque adjustment. This eliminates the accidents associate with key or tool operated balancers when adjusted after installation.
- The main body and dial are aluminum die cast to insure high durability for accidental impact with other balancers. The springs are of superior quality and have been tested under loaded to 300,000 cycles.

Specifications

Model	MHB-83-3
Media	Compressed Air
Max. Working Pressure	1MPa
Working Temp. Range	0~60 °C (23~142 °F)
Capacity	9.8~29.4N (2.2~6.6Lbs)
Stroke	1.3 m.
Hose	MH-8(8x10.5mm) (ID.5/16")
Weight	2.5kg (5.5Lbs)

ARX-10



HOSE REEL

ดัดสายลม รุ่น ARX-10 ทำหน้าที่คล้ายดัดสายไฟ เพียงดึงสายลม ออกมาให้ยาวตามที่ต้องการ อีกทั้งสะดวกในการเก็บ เพียงแค่กระดุกสายดัด จะทำหน้าที่ดึงสายเข้าไปเก็บเอง เนื้อสายลมทำจากโพลียูรีเทน แข็งแรง ไม่กรอบและรั่วซึมง่าย ช่วยให้สะดวกและประหยัดเวลาได้มาก

คุณสมบัติ

รุ่น	: ARX-10
ความยาวสายลม	: 10 เมตร
ขนาดสาย (ID)	: 6.5 มม.
แรงดันสูงสุด	: 15 Kg/cm ²
น้ำหนัก	: 4.1 Kg

ตัวตัดสายลม

TUBE CUTTER



Main Features

- This cutter allows plastic tube to be cut cleanly and at right angles. Tube up to 16mm. Dia can be accommodated.

Operation Precautions

- Please do not place the finger when you cut the tube
- Please check regularly and exchange the blade when it worsened

Dimensions

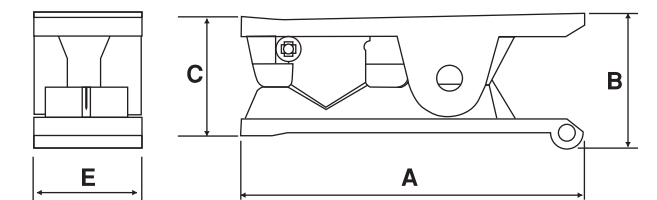

Specifications

Tube used	3~16 mm
Tube used Materials	Polyurethane, Nylon

Model	A	B	C	E	Weight (g)
TC-16	80.0	31.5	27.5	25.0	35.0