

NP คีมตัด - ปอกสายไฟ
Diagonal Cutting Nippers with Hole



▲ NP-150GH-S



▲ NP-140Z-S



▲ NP-150ZH-S



▲ NP-165Z

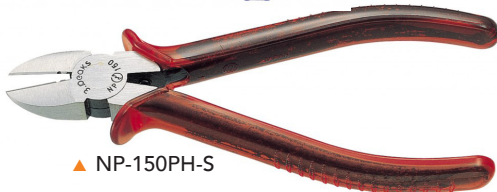

▲ NP-150PH-S



▲ DN-195

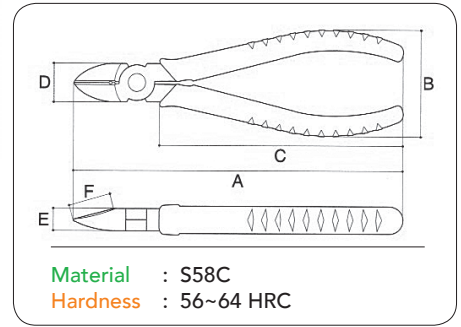

Code No.	Size (mm)	Length of each part (mm)						Grip		Cutting Capacity (mm)			
		A	B	C	D	E	F	Material	Spring	Iron Wire	Copper Wire	VVF2	Strand Wires (mm ²)
NP-125GH-S	125	132	51	86	15	9	15.5	Vinyl	Coil Spring	Ø1.5	Ø2.6	-	2.0
NP-150GH-S	150	162	52	110	19	11	20			Ø1.9	Ø3.2	Ø1.6	2.0
NP-150G-S (3 Holes)	150	162	52	110	19	11	20			Ø1.9	Ø3.2	Ø1.6	2.0
NP-125ZH-S	125	133	52	97	15	9	15.5	Elastomer	Plastic Spring	Ø1.5	Ø2.6	-	2.0
NP-140Z-S	140	148	48	110	17	10	18			Ø1.9	Ø3.2	Ø1.6	2.0
NP-150ZH-S	150	162	52	121	19	11	20			-	Ø1.9	Ø3.2	Ø1.6
NP-165Z	165	172	50	127	21	11	21.5	Plastic	Coil Spring	Ø1.5	Ø2.6	-	2.0
NP-125PH-S	125	133	52	99	15	9	15.5			Ø1.9	Ø3.2	Ø1.6	2.0
NP-150PH-S	150	162	52	125	19	11	20			Ø1.9	Ø3.2	Ø1.6	2.0
NP-150P-S (3 Holes)	150	162	52	125	19	11	20	Elastomer	-	Ø2.0	Ø3.2	Ø2.0	5.5
DN-195	195	205	51	151	24.5	12	26			Ø2.6	Ø4.0	Ø2.6(VVF3)	5.5
DN-215	215	225	51	164	27	13	29	Elastomer	-				

Note : NP-140Z-S and NP-165Z are not JIS Standard Products.

LN คีมตัด - ปอกสายไฟน้ำหนักเบา
Light - Diagonal Cutting Nippers



▲ LN-175



▲ LN-150S

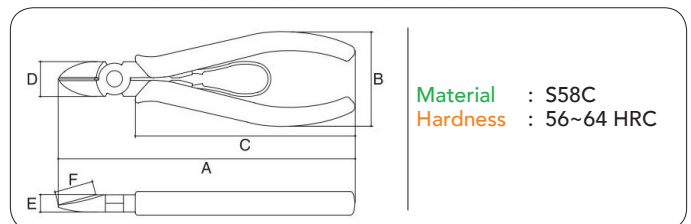
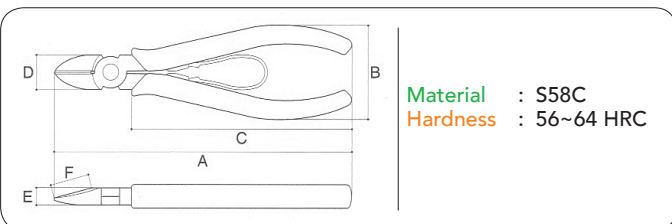

Code No.	Size (mm)	Length of each part (mm)						Grip		Cutting Capacity (mm)			
		A	B	C	D	E	F	Material	Spring	Iron Wire	Copper Wire	VVF2	Strand Wires (mm ²)
LN-125S	125	136	50	98	15	8.5	15.5	Elastomer	Plastic Spring	Ø1.5	Ø2.6	-	2.0
LN-150S	150	164	52	122	19	9.5	20			Ø1.9	Ø3.2	Ø1.6	2.0
LN-175	175	183	50	135	23	11	23.5			-	Ø2.2	Ø3.2	Ø1.6

Cutting Nippers

Pliers

Cutter

KW ประแจถอดไส้กรอง
Cartridge Wrenches

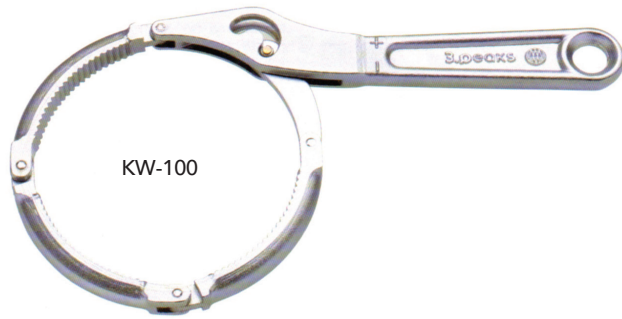

KW-100

OW ประแจถอดไส้กรองน้ำมันเครื่อง
Oil Filter Wrenches

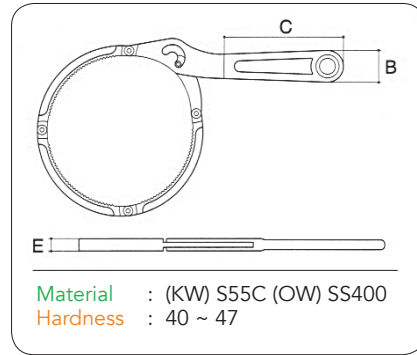

Code No.	Size (mm)	Length of each part (mm)					Grip		Range of Use (mm)
		A	B	C	D	E	Material	Spring	Filter Diameter
KW-100	200	-	26	97	-	8	Steel	-	Ø 55 ~ 75
KW-200	200	-	26	97	-	10			Ø 75 ~ 95
KW-300	200	-	26	97	-	10			Ø 95 ~ 115
KW-400	230	-	26	150	-	12			Ø 115 ~ 140
OW-100*	200	-	24.5	115	-	9			Ø 75 ~ 95

* ยกเลิกการผลิต

SS/SB/HS/HB คีมถ่างแหวนล๊อค / คีมหุบแหวนล๊อค
Snap Ring Pliers

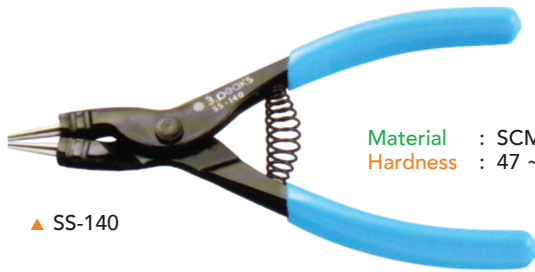

▲ SS-140

Material : SCM435
Hardness : 47 ~ 50



▲ HB-140

Code No.	Size (mm)	Length of each part (mm)					Tip Dia.	Grip		Range of Use (mm)	Type
		A	B	C	D	E		Material	Spring	Diameter of Locking Ring	
SS-140	140	150	75	46	8	-	1.3	Vinyl	Coil Spring	Ø 10 ~ 25	External Locking Ring
HS-140	140	148	75	43	8	-	1.3			Ø 12 ~ 25	

* ยกเลิกการผลิต

TS Coax Cable - Strippers

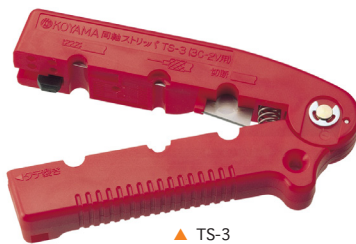

▲ TS-3

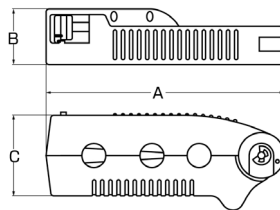

▲ TS-5

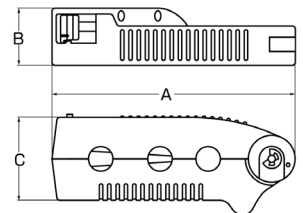

Code No.	Size (mm)	Length of each part (mm)					Grip		Range of Use (mm)	Peeling Capacity (mm)	
		A	B	C	D	E	Material	Spring	Applicable Code	Strand Wire (mm ²)	Cable
TS - 3	100	106	34	-	34	20	Plastic	Coil Spring	3C - 2V	-	-
TS - 5	100	106	34	-	34	20			5C - 2V • 5C - FB	-	-

DS-150/175 คีมจับหัวสกรูที่ชำรุด

Dia Type Pliers



▲ DS-175Z

DS-115TZ/150TZ/175TZ คีมจับหัวสกรูที่ชำรุด

Dia Type Pliers

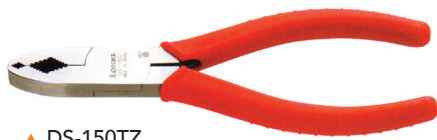

▲ DS-150TZ



▲ DS-115TZ

■ 各部の機能

先端くわえ部(小)

くわえ部前(小-先端と同寸)

くわえ部後(大)

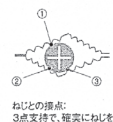
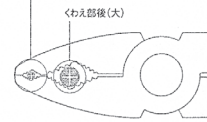

おじこの据点: 3点支持で、確実にねじを保持

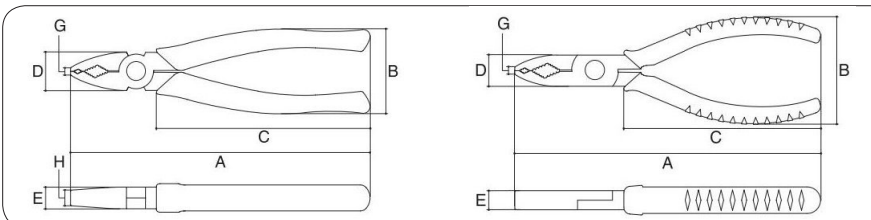

Material : S58C
Hardness : 50 ~ 58 (Chucking Part)

Code No.	Size (mm)	Length of each part (mm)								Grip		Range of Use (mm)		
		A	B	C	D	E	F	G	H	Material	Spring	Hex Screw	Machine Screw Pan Type	Machine Screw Trass Type
DS-150Z	150	150	52	98	15.3	9.4	-	4.5	9.4	Elastomer	-	2 ~ 8	M1.6 ~ M6	-
DS-175Z	175	175	49	126	22	12.5	-	4.5	9.4		-	2 ~ 8	M1.6 ~ M6	-
DS-115TZ	115	116.5	48	80	10.5	7.5	4	4.5	-		Plastic Spring	2	M1.0 ~ M2.6	M2
DS-150TZ	150	150	52	98	15.3	9.4	4.5	-	-		-	2 ~ 8	M1.6 ~ M6	M2 ~ 4
DS-175TZ	175	175	49	126	22	12.5	4.5	9.5	-		-	2 ~ 8	M1.6 ~ M6	M2 ~ 4
DS-215TZ	215	215	51	157	27	13	-	8	11		-	5 ~ 8	M2 ~ M8	M2 ~ 6

WPP คีมคอกน้ำ

Kuchi Pura - Water Pump Pliers / Box Joint - Water Pump Pliers



▲ WPP-250KP

• Type of Jaws



Straight Type

R - Type

Dia - Type

Kuchi Pura - Water Pump Pliers

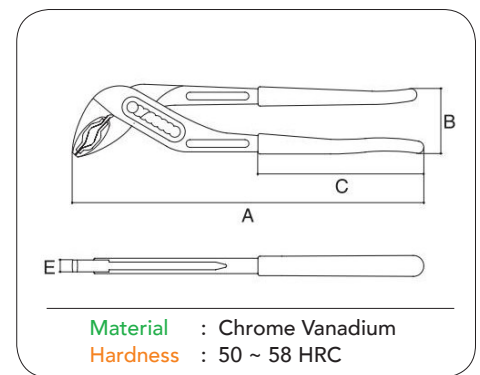

Material : Chrome Vanadium
Hardness : 50 ~ 58 HRC

Code No.	Size (mm)	Length of each part (mm)					Grip		Range of Use (mm)	
		A	B	C	D	E	Material	Spring	Hex Screw	Pipe Outer Diameter
WPP-250G	250	252	47	124	-	8	Vinyl	-	5.5 ~ 36	-
WPP-250RG	250	252	47	124	-	8		-	5.5 ~ 36	5.5 ~ 43
WPP-250DG	250	252	47	124	-	8		-	10 ~ 41	∅ 6 ~ 43
WPP-250KP	250	252	47	124	-	8		-	10 ~ 41	∅ 6 ~ 43
KP-01	Spare Jaw For WPP-250 KP									

Cutting Nippers

Pliers

Cutter

JC คีมตัดลวดทองคำ
Jewelry Cutters



▲ JC-220

JC-A คีมตัดลวดทองคำ-ปากบาง
Jewelry Cutters-Thin Blade Type



▲ JC-220A

Code No.	Size (mm)	Length of each part (mm)						Grip		Cutting Capacity (mm)			
		A	B	C	D	E	F	Material	Spring	Gold	Silver	Nickel	Silver Brass
JC-220	220	220	50	150	40	11.5	21	Steel	With Spring	Ø4.0	Ø4.0	Ø4.0	Ø4.0
JC-220A	220	220	50	150	40	11.5	21			Ø4.0	Ø4.0	Ø4.0	Ø4.0

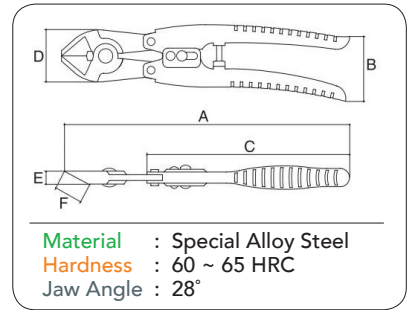

GC คีมตัดลวดเหล็ก
Green Cutters



▲ GC-200

GN คีมตัดลวดเหล็ก
Green Nippers



▲ GN-200J

▲ GN-200

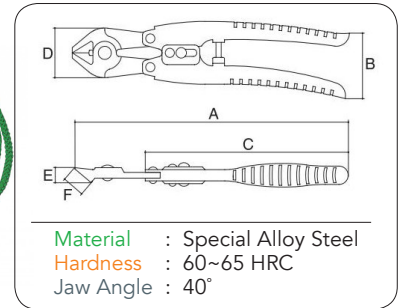
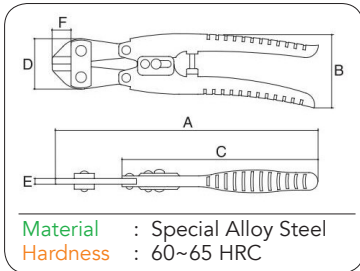

GN-200J

GN-200J

GN-200J

EC คีมตัดลวดเหล็ก
Green End Cutting Nippers



▲ EC-200

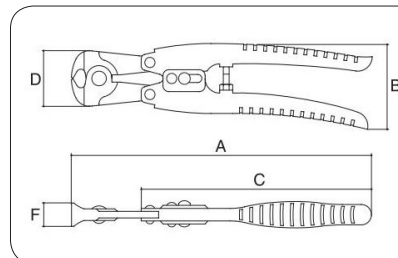

Code No.	Size (mm)	Length of each part (mm)						Grip		Cutting Capacity (mm)				
		A	B	C	D	E	F	Material	Spring	Steel Wire	Iron Wire	Copper Wire	VVF3	IV (mm ²)
GC - 200	200	211	48	150	40	4.5	15	Steel	With Spring	Ø1.5	Ø4.0	Ø4.0	-	-
GN - 200	200	213	48	150	38	10.5	15			Ø1.5	Ø4.0	Ø4.0	-	-
GN - 200J	200	213	48	150	38	10.5	15			Ø1.5	Ø4.0	Ø4.0	-	-
EC - 200	200	207	48	150	38	-	17			Ø1.5	Ø4.0	Ø4.0	-	-

DS-130T/130/200 คีมล็อคจับหัวสกรูที่ชำรุด
Daiya Type Vise



▲ DS-200

DS-130T

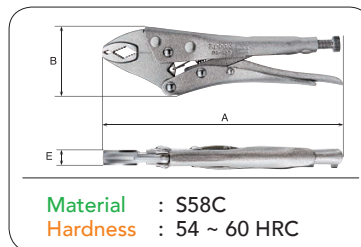

DS-130T / DS -200

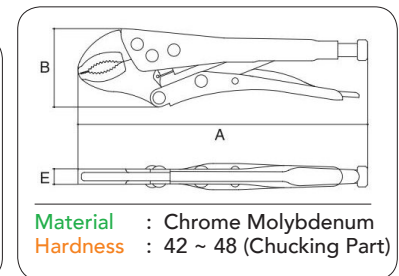

Code No.	Size (mm)	Length of each part (mm)						Grip		Cutting Capacity (mm)			Range of Use (mm)		
		A	B	C	D	E	F	Material	Spring	Iron Wire	Soft Steel Wire	Hex Bolt	Machine Screw Pan Type	Chucking Part	
DS-130T	130	140	38	-	-	9	-	Steel	With Spring	-	Ø1.2	2 ~ 4	Ø2.3 ~ 10 (M1.6 ~ M6)	3 ~ 13	
DS-130	130	138	38	-	-	7	-			-	Ø1.2	2 ~ 8	Ø2.3 ~ 9 (M1.6 ~ M5)	4 ~ 19	
DS-200	200	210	56	-	-	11	-			Ø1.5	-	2 ~ 8	Ø3.5 ~ 14 (M2 ~ M8)	9 ~ 40	

DF คีมตัดสายไฟ
Shear Pliers



▲ DF-195

Material : S58C
Hardness : 54~62 HRC

Code No.	Size (mm)	Length of each part (mm)						Grip		Cutting Capacity (mm)				
		A	B	C	D	E	F	Material	Spring	Iron Wire	Copper Wire	VVF3	VVF4	IV (mm ²)
DF-195	195	200	51	139	24	11.5	17.8	Elastomer	-	Ø2.0	Ø2.6	Ø2.0	-	14.0
DF-220	220	224	52	153	27	14	19.5			Ø2.0	Ø3.2	Ø2.6	Ø2.0	Ø2.0

KC คีมตัดสายเคเบิล
Cable Cutters



▲ KC-22



▲ KC-60

Material : S58C
Hardness : 50 ~ 55 HRC

WC คีมตัดลวด
Wire Cutters



▲ WC-165

Material : Special Alloy Steel
Hardness : 60~65 HRC

Code No.	Size (mm)	Length of each part (mm)						Grip		Cutting Capacity (mm)				
		A	B	C	D	E	F	Material	Spring	Iron Wire	Wire Rope	VVF3	VVF4	IV (mm ²)
KC - 22	160	161	45	93	27	11	18	Vinyl	-	-	-	Ø2.0	-	22.0
KC - 60	235	234	47	142	34	14	25		-	-	-	Ø2.6	Ø2.0	60.0
WC - 165	165	167	43	97	24	10.5	-	Spring	-	Ø4.0	-	-	-	-

WCC คีมย้ำ - ตัดลวดสลิง
Wire Clamp Cutters



▲ WCC-200



▲ WCC-250

Material : Special Alloy Steel
Hardness : 60~65 HRC

■ 各部の機能

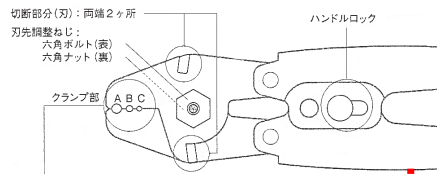

穴サイズ (mm)	※型はWCC-250			刻印=対応可能なワイヤロープサイズ (mm)		
	A	B	C	A	B	C
WCC-200	1.3	2.0	2.6	SS (0.10 / 0.19)	0.27 / 0.45	0.81 / 1.0
WCC-250	3.8	2.6	2.0	1.5	0.81 / 1.0	0.27 / 0.45

■ 刃先・開閉幅の調整方法

- ① スパナでナットをゆるめます
 - ② ボルトを締め、刃の開閉を確認します
 - ③ 適切な位置でナットを回し、確実に締め付けて固定します
- ※ ボルトの位置を動かさないでください
※ ナットの締め過ぎに注意してください

Code No.	Size (mm)	Length of each part (mm)						Grip		Cutting Capacity (mm)	
		A	B	C	D	E	F	Material	Spring	Iron Wire	Wire Rope
WCC-200	200	213	52	150	36	4.5	-	Vinyl	With Spring	-	Ø1.5
WCC-250	250	254	51	187	42	4.5	-	Steel		-	Ø3.0

Cutting Nippers

Pliers

Cutter

Cutting Nippers

Pliers

Cutter

Code No.SP-11 ~ SP-14
 Material : Carbon Steel SK85 (SK5)
 Hardness : 50 ~ 57 HRC

SP-11 คีมตัดลวด
 Cutting Nippers



SP-13 คีมตัดพลาสติก
 Plastic Nippers



SP-12 คีมตัดลวด
 Bent Cutting Nippers



SP-14 คีมตัดลวด
 Edge Cutting Nippers



Material : Stainless Steel
 Code No. : SP-21 ~ SP-23
 Hardness : 50~57 HRC
 Code No. : SP-24 ~ SP-27
 Hardness : 48~53 HRC

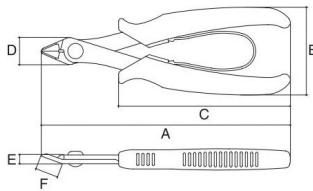

SP-24 คีมปากแหลม (ไม่มีฟัน) วัสดุเป็นสแตนเลส
 Stainless Needle - Flat Nose Pliers



SP-21 คีมตัดลวด วัสดุเป็นสแตนเลส
 Stainless Cutting Nippers



SP-25 คีมปากแหลมปากงอ (ไม่มีฟัน) วัสดุเป็นสแตนเลส
 Stainless Bent - Flat Nose Pliers



SP-22 คีมตัดลวด วัสดุเป็นสแตนเลส
 Stainless Bent Cutting Nippers



SP-26 คีมปากแบน (ไม่มีฟัน) วัสดุเป็นสแตนเลส
 Stainless Short - Flat Nose Pliers



SP-23 คีมตัดพลาสติก วัสดุเป็นสแตนเลส
 Stainless Plastic Nippers



SP-27 คีมปากกลม (ไม่มีฟัน) วัสดุเป็นสแตนเลส
 Stainless Round Nose Pliers



Code No.	Size (mm)	Length of each part (mm)									Grip		Cutting Capacity (mm)				
		A	B	C	D	E	F	G	H	I	Material	Spring	Plastic	Annealed Iron Wire	Copper Wire	Strand Wires (mm ²)	
SP - 11	125	126	44	79	14	4.6	10	-	-	-	Elastomer	Kick Spring	-	-	Ø1.6	2.0	
SP - 12	125	124	44	79	14	4.6	7	-	-	-			-	-	-	Ø1.0	2.0
SP - 13	125	126	44	79	14	4.6	10	-	-	-			Ø3.0	-	-	-	-
SP - 14	135	138	44	79	14	4.6	7	-	-	-			-	-	-	Ø0.6	2.0
SP - 21	125	126	44	79	14	4.6	10	-	-	-			-	-	-	Ø1.6	2.0
SP - 22	125	124	44	79	14	4.6	7	-	-	-			-	-	-	Ø1.0	2.0
SP - 23	125	126	44	79	14	4.6	10	-	-	-			Ø3.0	-	-	-	-
SP - 24	145	148	44	79	14	6	-	2	1.2	18			-	-	-	-	-
SP - 25	145	146	44	79	14	6	-	2	1.2	8			-	-	-	-	-
SP - 26	135	136	44	79	14	6	-	2	3	12			-	-	-	-	-
SP - 27	135	136	44	79	14	6	-	Ø3.0	Ø0.8	-			-	-	-	-	-

LS-01 คีมตัดลวด วัสดุเป็นสแตนเลส
Stainless - Cutting Nippers



▲ LS-01

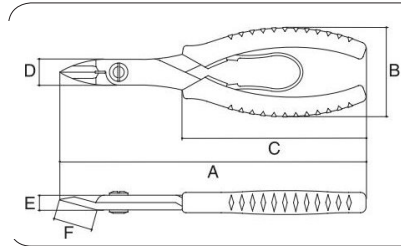

Material : Stainless Steel
Hardness : 52~57 HRC
Jaw Angle : 15°

LS-02 คีมตัดพลาสติก วัสดุเป็นสแตนเลส
Stainless - Plastic Nippers



▲ LS-02

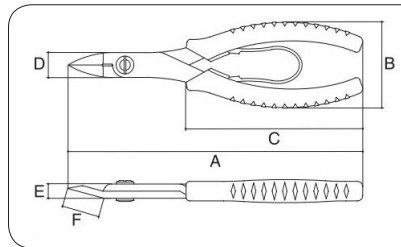

Material : Stainless Steel
Hardness : 52~57 HRC
Jaw Angle : 15°

LS-03 คีมปากแหลม (ไม่มีฟัน) วัสดุเป็นสแตนเลส
Stainless Long Nose Pliers



▲ LS-03

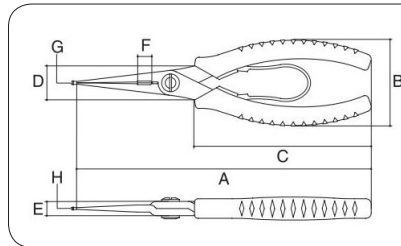

Material : Stainless Steel
Hardness : 50~55 HRC

LS-04 คีมปากแหลมปากงอ (ไม่มีฟัน) วัสดุเป็นสแตนเลส
Stainless Bent - Long Nose Pliers



▲ LS-04

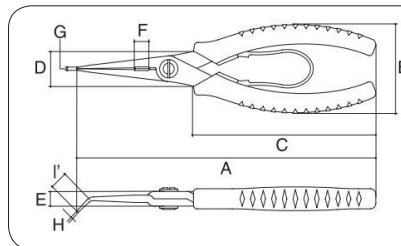

Material : Stainless Steel
Hardness : 50~55 HRC
Jaw Angle : 45°

LS-05 คีมปากแบน (ไม่มีฟัน) วัสดุเป็นสแตนเลส
Stainless Flat Nose Pliers



▲ LS-05

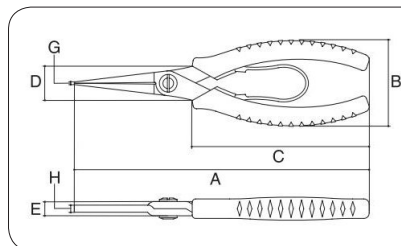

Material : Stainless Steel
Hardness : 50~55 HRC

Code No.	Size (mm)	Length of each part (mm)									Grip		Cutting Capacity (mm)				
		A	B	C	D	E	F	G	H	I	Material	Spring	Plastic	Annealed Iron Wire	Copper Wire	Strand Wires (mm ²)	
LS-01	165	166	48	97	14	8	19	-	-	-	Elastomer	Plastic Spring	-	Ø1.5	Ø2.6	2.0	
LS-02	165	166	48	97	14	8	18	-	-	Ø5.0			-	-	-		
LS-03	165	166	48	97	14	8	8	1.5	1	-			-	Ø1.5	Ø2.6	2.0	
LS-04	165	163	48	97	14	8	8	1.5	1	10			-	-	Ø1.5	Ø2.6	2.0
LS-05	165	166	48	97	14	8	-	1	4	-			-	-	-	-	

Cutting Nippers

Pliers

Cutter

Cutting Nippers

Pliers

Cutter

SP-31/SP-41

คีมตัดลวด วัสดุเป็นสแตนเลส
Stainless - Cutting Nippers



▲ SP-31



▲ SP-41

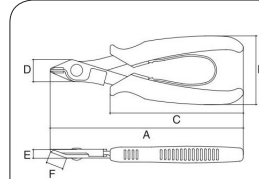

Material : Stainless Steel
Hardness : 50~57 HRC
Jaw Angle : 15°(Code No.SP-41)
Jaw Angle : 20°(Code No.SP-31)

SP-32/SP-42

คีมตัดลวด วัสดุเป็นสแตนเลส
Stainless - Bent Cutting Nippers



▲ SP-32

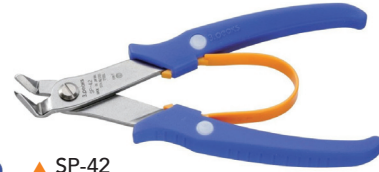

▲ SP-42

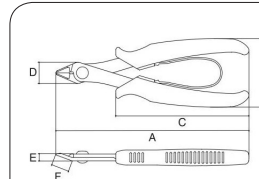

Material : Stainless Steel
Hardness : 50~57 HRC
Jaw Angle : 60°

SP-33/SP-43

คีมตัดพลาสติก วัสดุเป็นสแตนเลส
Stainless - Plastic Nippers



▲ SP-33

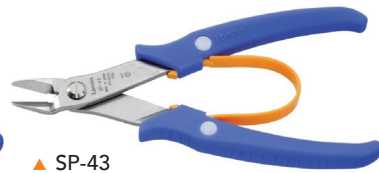

▲ SP-43

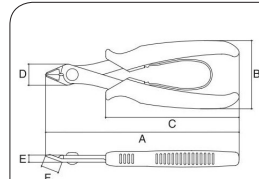

Material : Stainless Steel
Hardness : 50~57 HRC
Jaw Angle : 15°(Code No.SP-43)
Jaw Angle : 20°(Code No.SP-33)

Code No.	Size (mm)	Length of each part (mm)									Grip		Cutting Capacity (mm)			
		A	B	C	D	E	F	G	H	I	Material	Spring	Plastic	Annealed Iron Wire	Copper Wire	Strand Wires (mm ²)
SP-31	130	130	46	89	14	4.6	10	-	-	-	Elastomer	Plastic Spring	-	-	Ø1.6	2.0
SP-32	130	128	46	89	14	4.6	7	-	-	-	Elastomer	Plastic Spring	-	-	Ø1.0	2.0
SP-33	130	130	46	89	14	4.6	10	-	-	-	Elastomer	Plastic Spring	Ø3.0	-	-	-
SP-41	150	150	46	97	14	6	15	-	-	-	Elastomer	Plastic Spring	Ø4.0	Ø1.2	Ø2.0	2.0
SP-42	150	146	46	97	14	6	11	-	-	-	Elastomer	Plastic Spring	Ø4.0	Ø1.0	Ø1.6	2.0
SP-43	150	150	46	97	14	6	15	-	-	-	Elastomer	Plastic Spring	Ø4.0	-	-	-

SP-34

คีมปากแหลม (ไม่มีฟัน) วัสดุเป็นสแตนเลส
Stainless - Needle-Flat Nose Pliers



▲ SP-34

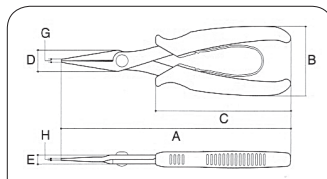

Material : Stainless Steel
Hardness : 48~53 HRC

SP-35

คีมปากแหลมปากงอ (ไม่มีฟัน) วัสดุเป็นสแตนเลส
Stainless - Bent-Flat Nose Pliers



▲ SP-35

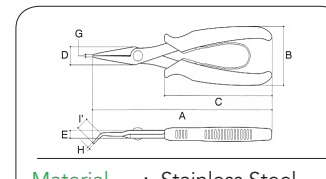

Material : Stainless Steel
Hardness : 48~53 HRC
Jaw Angle : 45°

SP-36

คีมปากแบน (ไม่มีฟัน) วัสดุเป็นสแตนเลส
Stainless Short - Flat Nose Pliers



▲ SP-36

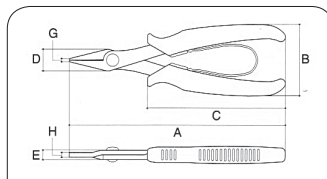

Material : Stainless Steel
Hardness : 48~53 HRC

SP-37

คีมปากกลม (ไม่มีฟัน) วัสดุเป็นสแตนเลส
Stainless Round Nose Pliers



▲ SP-37

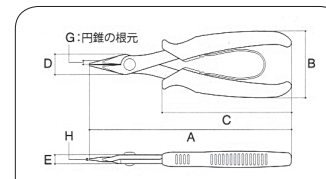

Material : Stainless Steel
Hardness : 48~53 HRC

Code No.	Size (mm)	Length of each part (mm)									Grip		Cutting Capacity (mm)			
		A	B	C	D	E	F	G	H	I	Material	Spring	Plastic	Annealed Iron Wire	Copper Wire	Strand Wires (mm ²)
SP-34	150	152	46	89	14	6	-	2	1.2	-	Elastomer	Plastic Spring	-	-	-	-
SP-35	150	149	46	89	14	6	-	2	1.2	10	Elastomer	Plastic Spring	-	-	-	-
SP-36	140	140	46	89	14	6	-	2	3	-	Elastomer	Plastic Spring	-	-	-	-
SP-36	140	140	46	89	14	6	-	Ø3.0	Ø0.8	-	Elastomer	Plastic Spring	-	-	-	-

SM-07/MFP

คีมปากแบน (ไม่มีฟัน)
Mini - Flat Nose Pliers



▲ SM-07



▲ MFP-115

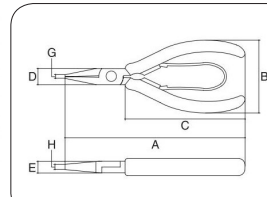

Material : SCrV
Hardness : 42~50 HRC

SM-05/SNP

คีมปากแหลม (ไม่มีฟัน)
Telephone - Short Needle Nose Pliers



▲ SM-05



▲ SNP-115

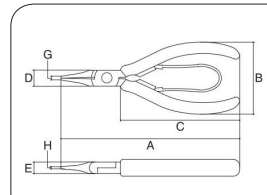

Material : SCrV
Hardness : 42~50 HRC

SM-03/NNP

คีมปากแหลม (ไม่มีฟัน)
Needle Nose Pliers



▲ SM-03



▲ NNP-130

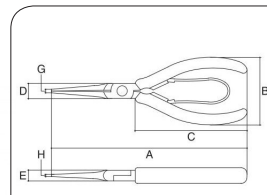

Material : SCrV
Hardness : 40~42 HRC

SM-04/NNP-B

คีมปากแหลมปากงอ (ไม่มีฟัน)
Bent Needle Nose Pliers



▲ SM-04



▲ NNP-130B

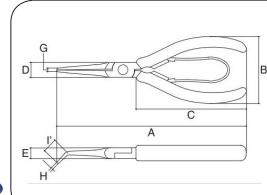

Material : SCrV
Hardness : 42~50 HRC
Jaw Angle : 45°

SM-08/RNP

คีมปากกลม (ไม่มีฟัน)
Round Nose Pliers



▲ SM-08



▲ RNP-115

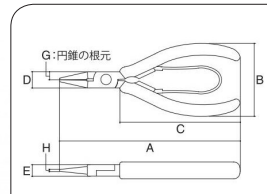

Material : SCrV
Hardness : 42~50 HRC

Code No.	Size (mm)	Length of each part (mm)									Grip		Cutting Capacity (mm)		
		A	B	C	D	E	F	G	H	I	Material	Spring	Iron Wire	Copper Wire	Strand Wires (mm ²)
SM-07	115	118	48	80	10.5	7.5	-	2.5	3.5	-	Elastomer	Plastic Spring	-	-	-
MFP-115	115	117	47	71	10.5	7.5	-	2.5	3.5	-	Vinyl	Coil Spring	-	-	-
SM-05	115	118	48	80	10.5	7.5	-	2.5	1.5	-	Elastomer	Plastic Spring	-	-	-
SNP-115	115	117	47	71	10.5	7.5	-	2.5	1.5	-	Vinyl	Coil Spring	-	-	-
SM-03	130	138	48	80	10.5	7.5	-	2.5	1.5	-	Elastomer	Plastic Spring	-	-	-
NNP-130	130	137	47	71	10.5	7.5	-	2.5	1.5	-	Vinyl	Coil Spring	-	-	-
SM-04	130	136	48	80	10.5	7.5	-	2.5	1.5	11	Elastomer	Plastic Spring	-	-	-
NNP-130B	130	135	47	71	10.5	7.5	-	2.5	1.5	11	Vinyl	Coil Spring	-	-	-
SM-08	115	118	48	80	10.5	7.5	-	∅5	∅1.2	-	Elastomer	Plastic Spring	-	-	-
RNP-115	115	117	47	71	10.5	7.5	-	∅5	∅1.2	-	Vinyl	Coil Spring	-	-	-

Cutting Nippers

Pliers

Cutter

Cutting Nippers

Pliers

Cutter

NNP คีมปากแหลมปากเล็กพิเศษ (ไม่มีฟัน) Needle Nose Pliers



▲ NNP-150G

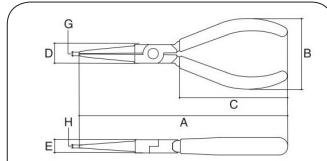

Material : SCrV
Hardness : 42~50 HRC

NNP-B คีมปากแหลมปากงอ ปากเล็กพิเศษ (ไม่มีฟัน) Bent Needle Nose Pliers



▲ NNP-150BG

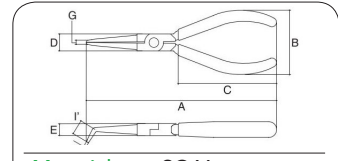

Material : SCrV
Hardness : 42~50 HRC
Jaw Angle : 60°

Code No.	Size (mm)	Length of each part (mm)									Grip		Cutting Capacity (mm)		
		A	B	C	D	E	F	G	H	I	Material	Spring	Iron Wire	Copper Wire	Strand Wires (mm ²)
NNP-150G	150	162	53	81	15	10	-	3	2	-	Vinyl	Spring	-	-	-
NNP-150BG	150	158	53	81	15	10	-	3	2	11	Vinyl	Coil Spring	-	-	-

FP คีมปากแบน Flat Nose Pliers



▲ FP-150G

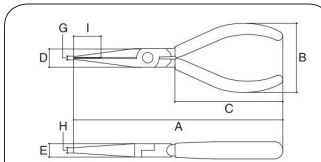

Material : S55C
Hardness : 40~50 HRC

SL/SL-B คีมปากแหลมปากตรง-ปากงอ วัสดุเป็นสแตนเลส Stainless - Long Nose Pliers / Stainless - Bent Long Nose Pliers



▲ SL - 150Z

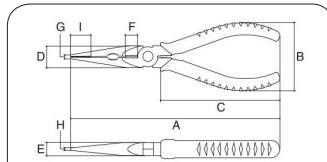

Material : Stainless Steel
Hardness : 48~54 HRC



▲ SL - 150BZ

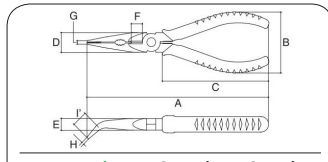

Material : Stainless Steel
Hardness : 48~54 HRC
Jaw Angle : 45°

• Handle (SL-150/SL-150B)



Code No.	Size (mm)	Length of each part (mm)									Grip		Cutting Capacity (mm)		
		A	B	C	D	E	F	G	H	I	Material	Spring	Iron Wire	Copper Wire	Strand Wires (mm ²)
FP-150G	150	158	52	82	15	10	-	2	4	21	Vinyl	Spring	-	-	-
SL-150	150	160	50	90	17	10	9.5	3	2	16	-	-	Ø1.5	Ø2.6	2.0
SL-150Z	150	163	53	92	17	10	9.5	3	2	16	Elastomer	-	Ø1.5	Ø2.6	2.0
SL-150B	150	156	50	90	17	10	9.5	3	2	16	-	-	Ø1.5	Ø2.6	2.0
SL-150BZ	150	159	53	92	17	10	9.5	3	2	16	Elastomer	-	Ø1.5	Ø2.6	2.0

TP คีมปากแหลม Telephone - Long Nose Pliers



▲ TP-150G-S

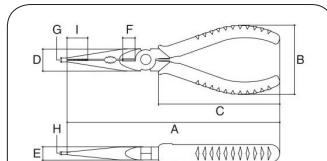

Material : SCrV
Hardness : 54~62 HRC



▲ TP-150P-S

BR คีมปากแหลม อนุกรมประสงค์ Multiple - Long Nose Pliers



▲ BR-150Z-S
• Multiple Jaws

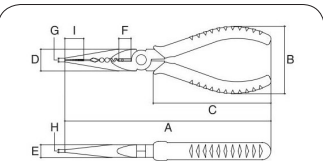
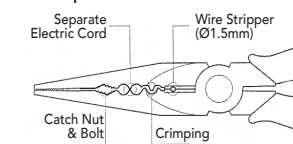

Material : SCrV
Hardness : 54~62 HRC

Code No.	Size (mm)	Length of each part (mm)									Grip		Cutting Capacity (mm)		
		A	B	C	D	E	F	G	H	I	Material	Spring	Iron Wire	Copper Wire	Strand Wires (mm ²)
TP-150G-S	150	162	53	82	17	10	9.5	3	2	16	Vinyl	Spring	Ø1.5	Ø2.6	2.0
TP-150Z-S	150	163	53	92	17	10	9.5	3	2	16	Elastomer	-	Ø1.5	Ø2.6	2.0
TP-150P-S	150	163	53	98	17	10	9.5	3	2	16	Plastic	-	Ø1.5	Ø2.6	2.0
BR-150G-S	150	162	53	82	17	10	9.5	3	2	14.5	Vinyl	Coil Spring	Ø1.5	Ø2.6	2.0
BR-150Z-S	150	163	53	92	17	10	9.5	3	2	14.5	Elastomer	-	Ø1.5	Ø2.6	2.0

CR-02 คีมปากแหลม Wire Craft - Long Nose Pliers



▲ CR-02

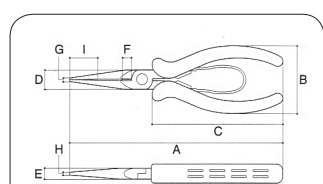

Material : SCrV
Hardness : 54~62 HRC

Code No.	Size (mm)	Length of each part (mm)									Grip		Cutting Capacity (mm)			
		A	B	C	D	E	F	G	H	I	Material	Spring	Iron Wire	Copper Wire	Aluminium Wire	Strand Wires (mm ²)
CR-02	150	157	50	95	14	8	7	2.5	2	20	Elastomer	Plastic Spring	Ø1.2	Ø2.6	Ø4.0	2.0

MC คีมปากจิ้งจกย้ายหางปลา - ปอกสายไฟ
Lineman's Crimp - Pliers



▲ MC-175Z



▲ DP-200 Material : Special Alloy Steel
Hardness : 58~65 HRC (Blade)

Specification for : MC-175~MC-200

• Wire Strippers and crimping Capacity

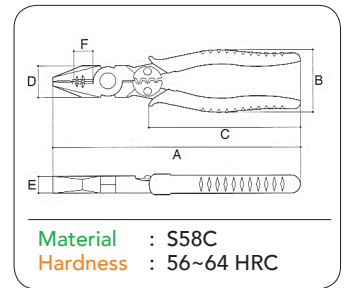
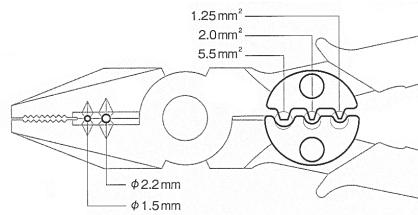

Material : S58C
Hardness : 56~64 HRC

Code No.	Size (mm)	Length of each part (mm)								Grip		Cutting Capacity (mm)			
		A	B	C	D	E	F	G	Material	Spring	Iron Wire	Copper Wire	VVF3	Strand Wires (mm²)	
MC-175G*	175	187	51	98	24	13.5	16	-	Vinyl	-	Ø2.8	Ø3.5	-	5.5	
MC-175Z*	175	187	51	114	24	13.5	16	-	Elastomer	-	Ø2.8	Ø3.5	-	5.5	
DP-200	200	200	51	140	24	12	20	-	Elastomer	-	Ø2.8	Ø3.5	Ø2.6	5.5	
DP-220	220	225	51	152	27	13	22	-	Elastomer	-	Ø3.4	Ø4.0	Ø2.6	5.5	

RP คีมปากแหลม
Long Nose Pliers



▲ RP-150G-S



▲ RP-140Z-S



▲ RP-150P-S

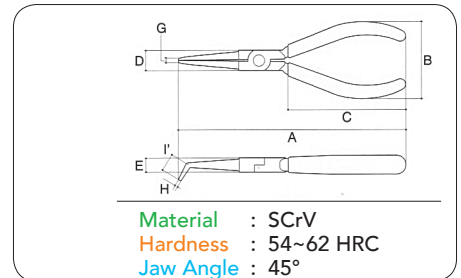

Material : SCrV
Hardness : 54~62 HRC
Jaw Angle : 45°

LR คีมปากแหลม น้ําหนักเบา
Light - Long Nose Pliers



▲ LR-150S



▲ RP-150BG

Code No.	Size (mm)	Length of each part (mm)										Grip		Cutting Capacity (mm)		
		A	B	C	D	E	F	G	H	I	Material	Spring	Iron Wire	Copper Wire	Strand Wires (mm²)	
RP-150BG	150	158	53	82	17	10	9.5	3	2	16	Vinyl	-	Ø1.5	Ø2.6	2.0	
RP-125G-S	125	141	48	71	15	9	9	2.8	1.8	18	Elastomer	Coil Spring	Ø1.5	Ø2.6	2.0	
RP-150G-S	150	162	53	82	17	10	9.5	3	2	24			Ø1.5	Ø2.6	2.0	
RP-125Z-S	125	143	48	80	15	9	9	2.8	1.8	18	Elastomer	Plastic Spring	Ø1.5	Ø2.6	2.0	
RP-140Z-S	140	150	50	88	16	9	9	2.8	1.8	18			Ø1.5	Ø2.6	2.0	
RP-150Z-S	150	163	53	92	17	10	9.5	3	2	24			Ø1.5	Ø2.6	2.0	
RP-165Z-S	165	173	52	102	17	10	9.5	3	2	24	Plastic	Coil Spring	Ø1.5	Ø2.6	2.0	
RP-150P-S	150	163	53	98	17	10	9.5	3	2	24			Ø1.5	Ø2.6	2.0	
LR-125S	125	144.5	49	82	15	8.5	9	2.8	1.8	18	Elastomer	Plastic Spring	Ø1.5	Ø2.6	2.0	
LR-150S	150	166	52	97	17	8.5	9.5	3	2	24			Ø1.5	Ø2.6	2.0	

MR คีมปากแหลมปากเล็กพิเศษ
Micro - Long Nose Pliers



▲ MR-150

MR-B คีมปากแหลมปากงอ ปากเล็กพิเศษ
Bent Micro - Long Nose Pliers



▲ MR-150B

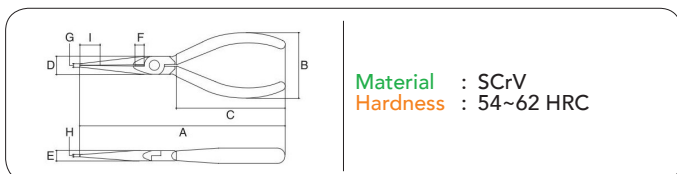

Material : SCrV
Hardness : 54~62 HRC

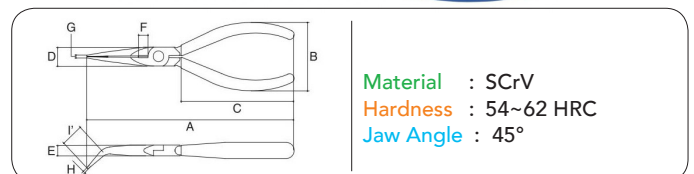

Material : SCrV
Hardness : 54~62 HRC
Jaw Angle : 45°

Code No.	Size (mm)	Length of each part (mm)										Grip		Cutting Capacity (mm)		
		A	B	C	D	E	F	G	H	I	Material	Spring	Iron Wire	Copper Wire	Strand Wires (mm²)	
MR-120	120	124	47	74	12	7.5	7	2.2	1.2	11.5	Vinyl	Coil Spring	Ø1.2	Ø2.6	2.0	
MR-150	150	160	51	84	14	8	7	2.2	1.2	20			Ø1.2	Ø2.6	2.0	
MR-150B	150	156	51	84	14	8	7	2.2	1.2	17			Ø1.2	Ø2.6	2.0	

* ยกเลิกการผลิต

SC/CP คีมปากจิ้งจก Side Cutting Pliers

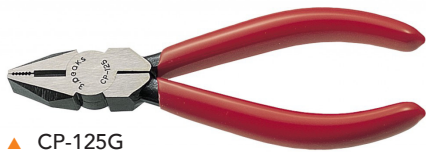

▲ CP-125G



▲ CP-140Z



▲ CP-150P



▲ SC-150G



▲ SC-150Z

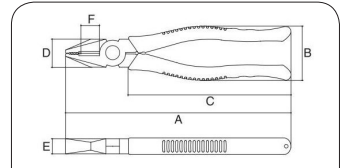

Material : S58C
Hardness : 56~64 HRC

Code No.	Size (mm)	Length of each part (mm)							Grip		Cutting Capacity (mm)			
		A	B	C	D	E	F	G	Material	Spring	Iron Wire	Copper Wire	VVF3	Strand Wires (mm ²)
CP-125G	125	128	47	82	17	10	10	-	Vinyl		Ø2.0	Ø2.6	-	3.5
CP-175G*	175	186	51	152	24	13.5	16	-			Ø2.8	Ø3.5	Ø1.6	5.5
CP-200G*	200	211	52	141	27	14.5	18	-			Ø3.4	Ø4.0	Ø2.0	5.5
CP-140Z	140	150	48.5	107	21	11.5	14	-	Elastomer		Ø2.2	Ø3.0	-	5.5
CP-165Z	165	176	49	126	22	12.5	16	-			Ø2.8	Ø3.5	Ø1.6	5.5
CP-175Z*	175	192	52	140	24	13.5	16	-			Ø2.8	Ø3.5	Ø1.6	5.5
CP-190Z	190	202	51	145	25	13.5	16.5	-	Plastic		Ø3.4	Ø4.0	Ø1.6	5.5
CP-200Z*	200	217	52	161	27	14.5	18	-			Ø3.4	Ø4.0	Ø2.0	5.5
CP-150P	150	164	49	120	23	12.5	14.5	-			Ø2.2	Ø3.0	-	5.5
CP-175P	175	189	52	136	24	13.5	16	-	Vinyl		Ø2.8	Ø3.5	-	5.5
CP-200P	200	214	54	156	27	14.5	17	-			Ø3.4	Ø4.0	-	5.5
SC-150G	150	161	48	105	22	12.5	14.5	-			Ø2.2	Ø3.0	Ø1.6	5.5
SC-175G	175	186	51	125	24	13.5	16	-	Elastomer		Ø2.8	Ø3.5	Ø1.6	5.5
SC-200G	200	211	52	141	27	14.5	18	-			Ø3.4	Ø4.0	Ø2.0	5.5
SC-150Z	150	167	49	121	22	12.5	14.5	-			Ø2.2	Ø3.0	Ø1.6	5.5
SC-175Z	175	192	52	140	24	13.5	16	-	Elastomer		Ø2.8	Ø3.5	Ø1.6	5.5
SC-200Z	200	217	52	161	27	14.5	18	-			Ø3.4	Ø4.0	Ø2.0	5.5

Note : CP-140Z, CP-165Z and CP-190Z are not JIS Standard Products.

* ยกเลิกการผลิต

LP คีมปากจิ้งจก น้ำหนักเบา Light - Side Cutting Pliers



▲ LP-150

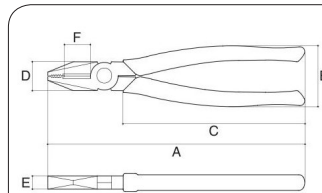

Material : S58C
Hardness : 56~64 HRC

Code No.	Size (mm)	Length of each part (mm)							Grip		Cutting Capacity (mm)			
		A	B	C	D	E	F	G	Material	Spring	Iron Wire	Copper Wire	VVF3	Strand Wires (mm ²)
LP-150	150	164	48	115	22	10	18	-	Elastomer		Ø2.2	Ø3.0	Ø2.0	5.5
LP-175	175	189	50	135	23	11	20	-			Ø2.8	Ø3.5	Ø2.6	5.5
LP-200	200	215	51	153	24	11	22	-			Ø3.4	Ø4.0	Ø2.6	5.5

PP คีมปากจิ้งจก น้ำหนักเบา Light - Side Cutting Pliers



▲ PP-170



▲ PP-200

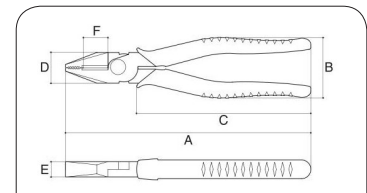

Material : SK85 (SK5)
Hardness : 62~67 HRC

Code No.	Size (mm)	Length of each part (mm)							Grip		Cutting Capacity (mm)				
		A	B	C	D	E	F	G	Material	Spring	Piano Wire	Iron Wire	Copper Wire	VVF3	Strand Wires (mm ²)
PP-170*	170	169	49	115	23	11.5	18	-	Elastomer		Ø2.0	Ø2.2	Ø3.0	Ø2.0	5.5
PP-195*	195	195	52	132	24	12.5	20	-			Ø2.0	Ø2.8	Ø3.5	Ø2.6	5.5
PP-200	200	200	51	140	24	12	20	-			Ø2.0	Ø2.8	Ø3.5	Ø2.6	5.5
PP-215*	215	217	54	150	27	13.5	22	-			Ø2.0	Ø3.4	Ø4.0	Ø2.6	5.5
PP-220	220	225	51	152	27	13	22	-			Ø2.0	Ø3.4	Ø4.0	Ø2.6	5.5

* ยกเลิกการผลิต

HP คีมตัดพลาสติก แบบเล็ก
High - Plastic Nippers



▲ HP-125



▲ HP-125R

Material : Special Alloy Steel
Hardness : 52~60 HRC

AP คีมตัดพลาสติก
Angle - Plastic Nippers



▲ AP-125G-S

Material : Special Alloy Steel
Hardness : 54~62 HRC

Code No.	Size (mm)	Length of each part (mm)						Grip		Cutting Capacity (mm)			
		A	B	C	D	E	F	Material	Spring	Plastic	Iron Wire	Copper Wire	Strand Wires (mm ²)
HP-125	125	132	48	96	14	8.5	15	Elastomer	Plastic Spring	Ø5.0	-	-	-
HP-125R	125	132	48	96	14	8.5	15			Ø5.0	-	-	-
AP-125G-S	125	132	51	85	14	15	23	Vinyl	Coil Spring	Ø5.0	-	-	-
AP-150G-S	150	157	53	104	15	16	25			Ø5.0	-	-	-

EP คีมตัดพลาสติก
Edge - Plastic Nippers



▲ EP-115



▲ EP-115R

Material : Special Alloy Steel
Hardness : 52~60 HRC

MTC คีมตัดพลาสติก
Mini - Top Cutters

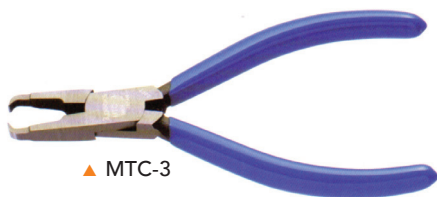

▲ MTC-3

TC คีมตัดพลาสติก
Top Cutters



▲ TC-10Z

Specification for : MTC, TC

Model MTC
Material : Special Alloy Steel
Hardness : 52~60 HRC
Model TC
Material : SCrV
Hardness : 52~60 HRC

Code No.	Size (mm)	Length of each part (mm)							Grip		Cutting Capacity (mm)			
		A	B	C	D	E	F	G	Material	Spring	Plastic	Iron Wire	Copper Wire	Strand Wires (mm ²)
EP-115	115	117	47	71	10.5	7.5	8.5	-	Vinyl	Coil Spring	Ø1.5	-	-	-
EP-115R	115	117	47	71	10.5	7.5	8.5	-			Ø1.5	-	-	-
MTC-3	115	117	47	71	10.5	7.5	3	7			Ø1.5	-	-	-
MTC-5	115	117	47	71	10.5	7.5	5	7			Ø1.5	-	-	-
TC-3Z	140	140	51	92	17	10	3	9	Elastomer	Coil Spring	Ø2.0	-	-	-
TC-5Z	140	140	51	92	17	10	5	9			Ø3.0	-	-	-
TC-7Z	140	140	51	92	17	10	7	9			Ø4.0	-	-	-
TC-10Z	150	150	48	87	18.5	10.5	10	13	Elastomer	Coil Spring	Ø4.0	-	-	-

Cutting Nippers

Pliers

Cutter

PNP คีมตัดพลาสติก
Plastic Nippers (Flat type)

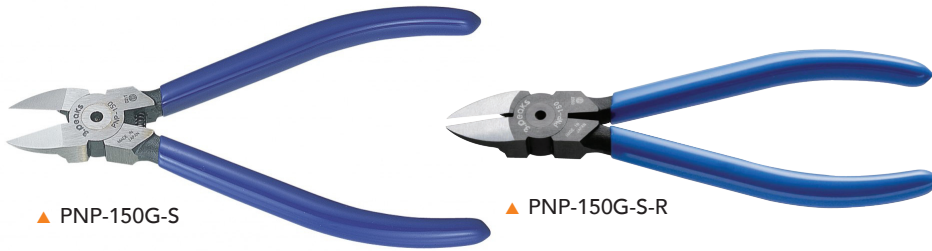

▲ PNP-150G-S

▲ PNP-150G-S-R

Material : S58C
The Nippers Length 190mm
Material : Special Alloy Steel
Hardness : 52~60 HRC

Code No.	Size (mm)	Length of each part (mm)						Grip		Cutting Capacity (mm)			
		A	B	C	D	E	F	Material	Spring	Plastic	Iron Wire	Copper Wire	Strand Wires (mm ²)
PNP-125G-S	125	132	51	86	15	9	13	Vinyl	Coil Spring	Ø5.0	-	-	-
PNP-150G-S	150	162	51	110	19	11	18			Ø5.0	-	-	-
PNP-190G-S	190	197	49	132	22	12	21			Ø8.0	-	-	-
PNP-125G-S-R	125	132	51	86	15	9	13			Ø5.0	-	-	-
PNP-150G-S-R	150	162	51	110	19	11	18			Ø5.0	-	-	-
PNP-190G-S-R	190	197	49	132	22	12	21			Ø8.0	-	-	-

LPN คีมตัดพลาสติก น้ำหนักเบา
Light - Plastic Nippers



▲ LPN-150S

Material : S58C
Hardness : 52~60 HRC

Code No.	Size (mm)	Length of each part (mm)						Grip		Cutting Capacity (mm)			
		A	B	C	D	E	F	Material	Spring	Plastic	Iron Wire	Copper Wire	Strand Wires (mm ²)
LPN-125S	125	136	50	98	15	8.5	13	Elastomer	Plastic Spring	Ø5.0	-	-	-
LPN-150S	150	164	52	122	19	9.5	18			Ø5.0	-	-	-

SM-02/MPN-100 คีมตัดพลาสติก แบบเล็กพิเศษ
Mini - Plastic Nippers



▲ MPN-100

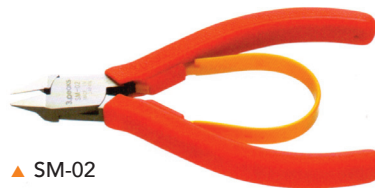

▲ SM-02

Material : Special Alloy Steel
Hardness : 57~62 HRC

MPN-125/MK-02 คีมตัดพลาสติก แบบเล็ก
Micro - Plastic Nippers / Model - Pro Nippers



▲ MPN-125

▲ MPN-125R



▲ MK-02

Specification for :
MPN-125, MPN-125R

Material : S58C
Hardness : 54~60 HRC

Material : S58C
Hardness : 52~60 HRC

Code No.	Size (mm)	Length of each part (mm)						Grip		Cutting Capacity (mm)			
		A	B	C	D	E	F	Material	Spring	Plastic	Iron Wire	Copper Wire	Strand Wires (mm ²)
SM-02	100	108	48	80	10.5	7.5	8.5	Elastomer	Plastic Spring	Ø3.0	-	-	-
MPN-100	100	107	47	71	10.5	7.5	8.5	Vinyl	Coil Spring	Ø3.0	-	-	-
MPN-125	125	125	50	87	12	7.5	11.5			Ø3.0	-	-	-
MPN-125R	125	125	50	87	12	7.5	11.5			Ø3.0	-	-	-
MK-02	120	121	50	92	11	6	11.5	Elastomer	Plastic Spring	Ø3.0	-	-	-

CR-01 คีมตัดลวด
Wire Craft - Cutting Nippers



▲ CR-01

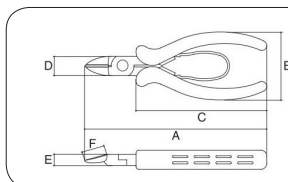

Material : Special Alloy Steel
Hardness : 56~64 HRC

Code No.	Size (mm)	Length of each part (mm)							Grip		Cutting Capacity (mm)					
		A	B	C	D	E	F	G	H	I	Material	Spring	Iron Wire	Copper Wire	Aluminium Wire	Strand Wires (mm ²)
CR-01	130	134	50	96	14	8.3	17	-	-	-	Elastomer	Plastic Spring	Ø1.5	Ø2.6	Ø4.0	-

SN คีมตัดลวด
Precision Nippers



▲ SN-130

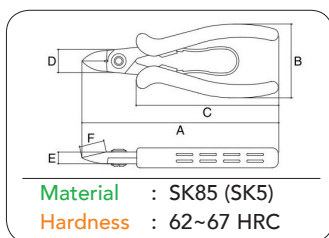

Material : SK85 (SK5)
Hardness : 62~67 HRC

AN คีมตัดลวด วัสดุเป็นอลูมิเนียมผสมอัลลอย
ALUMINIUM ALLOY STEEL (BODY)
CR - DIAGONAL CUTTING NIP



▲ AN-190

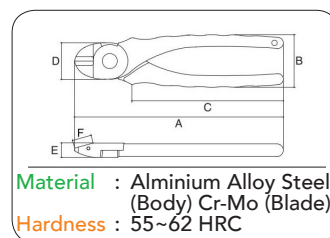

Material : Aluminium Alloy Steel (Body) Cr-Mo (Blade)
Hardness : 55~62 HRC

Code No.	Size (mm)	Length of each part (mm)						Grip		Cutting Capacity (mm)			
		A	B	C	D	E	F	Material	Spring	Paino Wire	Iron Wire	Copper Wire	Strand Wires (mm ²)
SN-130	130	133	51	96	16	8	15	Elastomer	Plastic Spring	Ø0.5	Ø2.0	Ø3.2	2.0
AN-190	190	190	48	152	33	13	17	-	-	-	Ø1.9	Ø2.6	2.0

DNP Angle Cutting Nippers With Hole



▲ DNP-150GH



▲ DNP-150ZH-S

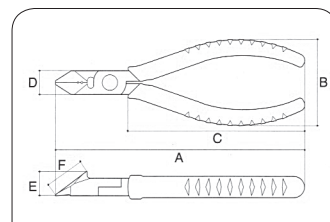

Material : Special Alloy Steel
Hardness : 57~62 HRC

Code No.	Size (mm)	Length of each part (mm)						Grip		Cutting Capacity (mm)			
		A	B	C	D	E	F	Material	Spring	Iron Wire	Copper Wire	VVF2	Strand Wires (mm ²)
DNP-125GH	125	132	51	82	14	15	23	Vinyl	-	Ø1.2	Ø2.0	-	2.0
DNP-150GH	150	157	53	104	15	16	25			Ø1.4	Ø2.0	Ø1.6	2.0
DNP-125ZH	125	133	52	93	14	15	23	Elastomer	-	Ø1.2	Ø2.0	-	2.0
DNP-150ZH	150	158	54	112	15	16	25			Ø1.4	Ø2.0	Ø1.6	2.0
DNP-125GH-S	125	132	51	81	14	15	23	Vinyl	Coil Spring	Ø1.2	Ø2.0	-	2.0
DNP-150GH-S	150	157	53	104	15	16	25			Ø1.4	Ø2.0	Ø1.6	2.0
DNP-125ZH-S	125	133	52	93	14	15	23	Elastomer		Ø1.2	Ø2.0	-	2.0
DNP-150ZH-S	150	158	54	112	15	16	25			Ø1.4	Ø2.0	Ø1.6	2.0

SPN คีมตัดพลาสติก ตัวพอมพิเศษ
Slim - Plastic Nippers



▲ SPN-165S

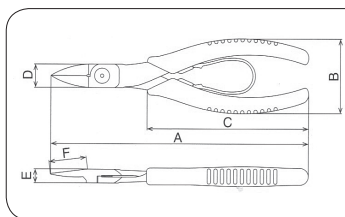

Material : Special Alloy Steel
Hardness : 52~60 HRC

Code No.	Size (mm)	Length of each part (mm)						Grip		Cutting Capacity (mm)			
		A	B	C	D	E	F	Material	Spring	Plastic	Iron Wire	Copper Wire	Strand Wires (mm ²)
SPN-145S	145	147	48	95	13	8	19	Elastomer	Plastic Spring	Ø3.0	-	-	-
SPN-165S	165	167	48	105	15	9	22			Ø5.0	-	-	-

Cutting Nippers

Pliers

Cutter

PN คีมตัดลวดงานหนัก
Power Nippers



▲ PN-165

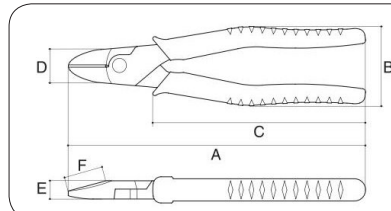

Material : SK85 (SK5)
Hardness : 62~67 HRC

NP-190 คีมตัดลวดงานหนัก
Heavy Duty - Diagonal Cutting Nippers

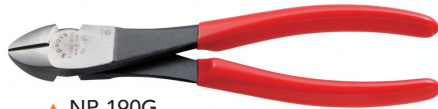

▲ NP-190G



▲ NP-190P



▲ NP-190BZ (Bent Type)

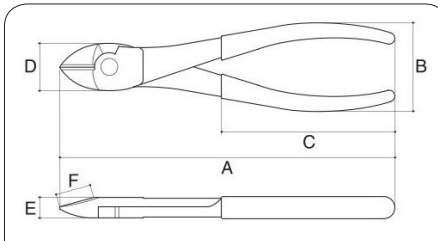

Material : SK85 (SK5)
Hardness : 62~67 HRC

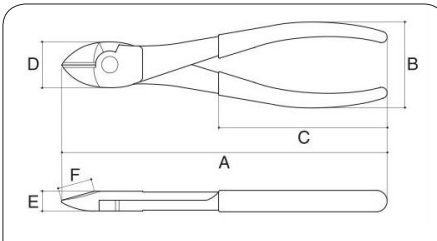

Material : SK85 (SK5)
Hardness : 62~67 HRC

Dimension for model NP-190BZ

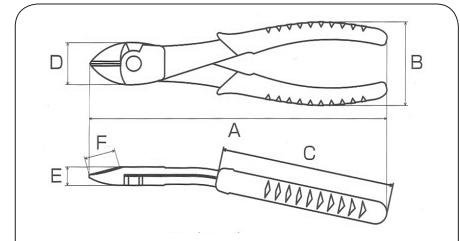

Material : SK85 (SK5)
Hardness : 62~67 HRC

Code No.	Size (mm)	Length of each part (mm)						Grip		Cutting Capacity (mm)				
		A	B	C	D	E	F	Material	Spring	Piano	Iron Wire	Copper Wire	VVF2	Strand Wires (mm ²)
PN-165	165	168	49.5	122	21	11	20.5	Elastomer		Ø1.0	Ø1.9	Ø3.2	Ø1.6	5.5
PN-185	185	187.5	50	135	23	11.5	23.5			Ø1.2	Ø2.15	Ø3.5	Ø1.6	5.5
NP-190G	190	197	53	109	28	12	20	Vinyl	-	Ø2.0	Ø2.6	Ø3.2	Ø1.6	5.5
NP-190P	190	198	53	120	28	12	20	Plastic		Ø2.0	Ø2.6	Ø3.2	Ø1.6	5.5
NP-190BZ	190	195	53	110	28	12	20	Elastomer		Ø2.0	Ø2.6	Ø3.2	Ø1.6	5.5

SM-01/MMP/MP/MK/SM-06/ENP คีมตัดลวด
Mini - Micro Nippers



▲ SM-01



▲ SM-06

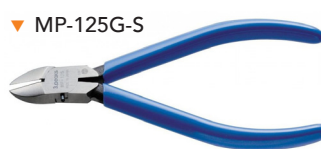

▼ MP-125G-S



▼ MK-01



▲ MMP-100



▲ ENP-115

Specification for : SM-01, MMP-100, SM-06, ENP-115

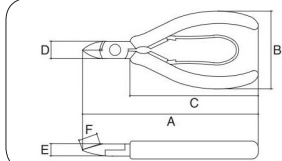

Material : Special Alloy Steel
Hardness : 57~62 HRC

Specification for : MP-125G-S, MK-01

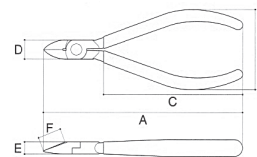

Material : S58C
Hardness : 54~60 HRC (MK-01)
: 57~63 HRC (MP-125G-S)

Code No.	Size (mm)	Length of each part (mm)						Grip		Cutting Capacity (mm)				
		A	B	C	D	E	F	Material	Spring	Iron Wire	Copper Wire	Brass	Plastic	Strand Wires (mm ²)
SM-01	100	108	48	80	10.5	7.5	10	Elastomer	Plastic Spring	-	Ø1.6	-	-	2.0
MMP-100	100	107	47	71	10.5	7.5	10	Vinyl	Coil Spring	-	Ø1.6	-	-	2.0
MP-125G-S	125	125	50	87	12	7.5	12			Ø1.2	Ø2.0	-	-	2.0
MK-01	120	121	50	92	11	6	11.5	Elastomer	Plastic Spring	-	Ø1.0	Ø0.6	Ø3.0	1.25
SM-06	115	118	48	80	10.5	7.5	8.5	Elastomer	Plastic Spring	-	Ø1.0	-	-	2.0
ENP-115	115	117	47	71	10.5	7.5	8.5	Vinyl	Coil Spring	-	Ø1.0	-	-	2.0